

# Series and Parallel Arc Fault Detection Based on Discrete Wavelet vs. FFT Techniques

Elaf Abed Saeed\*, Khalid M. Abdulhassan, Osama Y. Khudair  
Electrical Engineering Department, University of Basrah, Basrah, Iraq

## Correspondence

\*Elaf Abed Saeed  
Electrical Engineering Department  
University of Basrah, Basrah, Iraq.  
Email: elaphabd96@gmail.com

## Abstract

*Arc problems are most commonly caused by electrical difficulties such as worn cables and improper connections. Electrical fires are caused by arc faults, which generate tremendous temperatures and discharge molten metal. Every year, flames of this nature inflict a great lot of devastation and loss. A novel approach for identifying residential series and parallel arc faults is presented in this study. To begin, arc faults in series and parallel are simulated using a suitable simulation arc model. The fault characteristics are then recovered using a signal processing technique based on the fault detection technique called Discrete Wavelet Transform (DWT), which is built in MATLAB/Simulink. Then came db2, and one level was discovered for obtaining arc-fault features. The suitable mother and level of wavelet transform should be used, and try to compare results with conventional methods (FFT-Fast Fourier Transform). MATLAB was used to build and simulate arc-fault models with these techniques.*

**KEYWORDS:** Arc fault, Discrete wavelet transform (DWT), Fast Fourier Transform, Parallel arc fault model, Series arc fault model.

## I. INTRODUCTION

Electrical fires are one of the most dangerous and prevalent hazards of the twenty-first century. Over 2000 fires are recorded in Europe each year, according to Fire Safe Europe, a European organization committed to building fire safety, with buildings accounting for 90% of all occurrences in the EU. Every year, over 4,000 people are killed by fire in Europe, an average of 11 people each day. 7000 people are hospitalized to hospitals in Europe each year as a consequence of serious fire injuries. [1]. As a result, the arc fault is one of the causes. Series and parallel arc faults are the two forms of arc faults. When a single power conductor fails, the first and most typical kind occurs. Between the neutral/ground and phase conductors, a parallel arc fault arises.

Arc faults are detected using a variety of approaches, including Arc Fault Circuit Interrupted (AFCI), Short-Time Fourier Transform method, and Fast Fourier Transform. In 1998, the Arc Fault Circuit Interrupter (AFCI) was introduced. The AFCI's intended duty of identifying arcs that may contribute to fire triggers is explained in this presentation. It compares the AFCI to overcurrent protection equipment and ground-fault circuit interrupters; current ratings for AFCI devices are 15 and 20 A at 120 V, respectively. Industrial and commercial devices are now unavailable. However, the technology lends itself well to

these needs as long as the computer is geared to the load [2]. Detection and Implementation of Series Arc Faults In 2010, based on the Short-time Fourier Transform. This technique presents a substantial sequence arc fault detection method based on three parameters to the 50Hz fundamental variable, even and odd harmonics, using the STFT (STFT). The detection algorithm's viability is partially validated by results from a series of arc fault prediction tests and unintentional tripping tests [3]. They also invented Fast Fourier Transform-Based Real-Time Series AC Arc Fault Detection. The Fast Fourier Transform was used to detect real-time series AC arc faults in 2018. Using this tool, you can identify current interference and compute the arcing fault state on the device based on the spectrum from the FFT measurement. This method, however, is inapplicable to power-supply current with interruptions. Another problem with FFT is the picket fence effect (resolution bias error), which arises when a signal generates harmonics that are not integral multiples of the resolution frequency [4].

In this paper, a suitable Simulink of series and parallel arc faults is based on the arc gap energy-balance theory and is created in MATLAB/Simulink. The arc current signal's transient data is extracted using the discrete wavelet transform. The fault moment is then calculated by analyzing the singularity of the fault signal. The simulation results demonstrate that this model is capable of accurately



This is an open access article under the terms of the Creative Commons Attribution License, which permits use, distribution and reproduction in any medium, provided the original work is properly cited

© 2021 The Authors. Published by Iraqi Journal for Electrical and Electronic Engineering by College of Engineering, University of Basrah.

reflecting the features of real-world series and parallel faults. Moreover, to investigate the various arc detection technologies that are currently available and to evaluate their limitations. With the use of MATLAB simulation, examine and execute the new approach, Wavelet Transformation, and compare the results with the traditional method (FFT-Fast Fourier Transform).

## II. SERIES AND PARALLEL ARC FAULT MODEL

Arc faults may be classified into two types: series and parallel. The much more prevalent form of model is depicted in Fig. 1 (a), and it occurs when a single power conductor breaks. As a result of the connection in series, the maximum arc current is restricted by the load current, which is substantially less than the CB rated current, and the arc current may or may not create enough heat to ignite a fire, dependent on the load. [5].

When the insulator is damaged by mechanical, thermal stress, or aging, a parallel arc fault occurs between the neutral/ground and phase conductor [6]. The high-impedance arc melts and carbonizes the insulator first in this condition, following by the creation of the low-impedance current path. Intense temperatures cause the trail to develop, and if left unchecked, it might ignite a fire.

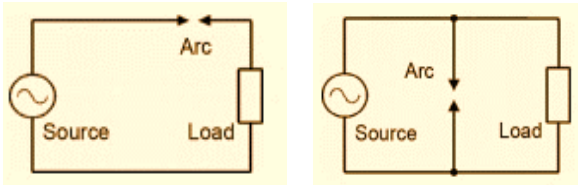

Fig. 1: (a) Series arc-fault. (b) Parallel arc fault.

### A. Arc mathematical model

The arc fault is described as a self-sustaining electrical discharge in conductive ionized gas [7], with circuit operation conditions limiting the maximum current. Arc may simply shorten the life of electrical devices or it can get dangerous (for example, in metal conductors) and cause spectacular occurrences like fires and explosions. The arc fault is nonlinear, discontinuous, and lacks sinusoidal features.

There are several models that may be used to characterize its behavior. Cassie (for analyzing the arc under high current and high plasma ambient temperature) and Mayr's arc model are one of the most recognized. [8]. The latter maintains a constant arc diameter and power loss and represents arc conductance around zero current. This model is excellent for arc fault modeling in residential and office wiring since it works well for very low currents (tens of Amperes). Mayr arc model is based on energy balance theory, accordingly

Mayr's arc fault model expression [9]:

$$\frac{dq}{dt} = e \times i - P_{loss} \quad (1)$$

Where:

$\frac{dq}{dt}$ : storage energy variations per arc length

$e \times i$ : input power per unit arc length.

$i$ : arc current.

$e$ : electric intensity in arc column.

$P_{loss}$ : power loss per unit arc length.

The model may be stated in the form of conductance since the arc resistance value is relatively small [10].

$$g = \frac{1}{R} = \frac{i}{u} = F(q(t)) \quad (2)$$

$$\frac{dg}{dt} = \frac{d}{dt} \left( \frac{1}{R} \right) = \frac{dF(q)}{dq} \times \frac{dq}{dt} = (e \times i) \times \frac{dF(q)}{dq} \quad (3)$$

For Mayr's arc model, the differential equation given by:

$$F(q) = k \times e^{q/q_0} \quad (4)$$

$$\frac{dg}{dt} = (e \times i) \times \frac{k}{q_0} \times e^{q/q_0} \quad (5)$$

$$\frac{dg}{dt} = (e \times i - P_{loss}) \times \frac{1}{q_0} \times F(q) \quad (6)$$

$$\frac{dg}{dt} = (e \times i - P_{loss}) \times \frac{g}{q_0} \quad (7)$$

$$\frac{1}{g} \times \frac{dg}{dt} = \frac{P_{loss}}{q_0} \times \left( \left( \frac{e \times i}{P_{loss}} \right) - 1 \right) \quad (8)$$

Let  $T = \frac{q_0}{P_{loss}}$

$$\frac{1}{g} \times \frac{dg}{dt} = \frac{1}{T} \times \left( \left( \frac{e \times i}{P_{loss}} \right) - 1 \right) \quad (9)$$

$$\frac{1}{g} \times \frac{dg}{dt} = \frac{1}{T} \times \left( \left( \frac{L \times e \times i}{L \times P_{loss}} \right) - 1 \right) \quad (10)$$

$$\frac{1}{g} \times \frac{dg}{dt} = \frac{1}{T} \times \left( \left( \frac{u \times i}{P_0} \right) - 1 \right) \quad (11)$$

Where:

$u$ : arc voltage,  $u = L \times e$

$P_0$ : Power loss in arc column,  $P_0 = L \times P_{loss} = u_c^2 \times g$

$u_c$ : arc voltage constant

$g$ : arc conductance

$$\frac{1}{g} \times \frac{dg}{dt} = \frac{1}{T} \times \left( \left( \frac{u \times i}{u_c^2 \times g} \right) - 1 \right) \quad (12)$$

$i = u \times g$

$$\frac{1}{g} \times \frac{dg}{dt} = \frac{1}{T} \times \left( \left( \frac{u^2}{u_c^2} \right) - 1 \right) \quad (13)$$

$$\frac{d \ln g}{dt} = \frac{1}{T} \times \left( \left( \frac{u^2}{u_c^2} \right) - 1 \right) \quad (14)$$

### B. Model parameters

#### 1) Determination of T

T: is the time constant of the arc fault, and can be expressed as below:

$$T = \frac{\alpha \times L_p}{L_p} \quad (15)$$

Where:

$I_p$ : is the peak current in the arc volt-ampere characteristic curve.  $I_p = 25A$

Alpha is the empirical value [9], take  $\alpha = 2.9 \times 10^{-5}$

$L_p$ : is the arc length which is approximate-constant [9].

$L_p = 2mm$

#### 2) Determination of $u_c$

It is a constant voltage of arc and is expressed below [9]:

$$u_c = 25 \times L_p \quad (16)$$

### III. ARC FAULT SIMULATION AND ANALYSIS

#### A. Series arc simulation analysis

It is developed simulation circuit design for assessing the efficacy of the arc in MATLAB/Simulink platform. The following are the arc simulation model parameters in this case are listed in table (1), the simulation time ranges from 0 to 0.2 seconds, after which an arc current is generated by using Controlled Current Source and measured using the AM1 block. The VM1 block calculates the voltage across the arc, and  $R_{load} = 5\Omega$  represents load resistance (constants resistance of the load is assumed).

The differential equation editor (DEE) block is used to describe Mayr arc model as shown in Fig.2.this block is also calculating the arc current  $i_{out}$  [9]:

$$i_{out} = e^x \times u \tag{16}$$

$$x_0 = \log g_0 \tag{17}$$

$$g_0 = 1e^4 sm \tag{18}$$

Where:  $g_0$  is the initial condition (initial arc conductivity). The user defined function is used to build the arc fault, so when the voltage source reach to a certain value the arc initiated, the proposed MATLAB/Simulink model is shown in from Fig.3.

#### B. Parallel arc simulation analysis

In the parallel arc model, the simulation analysis is the same as the series arc fault analysis with the same model parameters as listed in table (2), however the difference the arc is controlled by using unit step function, and arc start time is 0.05 sec, the load is short circuit for parallel arc fault [11], the proposed Simulation model is shown in Fig.4.

In the simulation model of series and parallel shown in Fig.3. and Fig.4 respectively, with model parameters, the

simulation of arc current waveforms of these models is shown in Fig.5 and Fig.6.

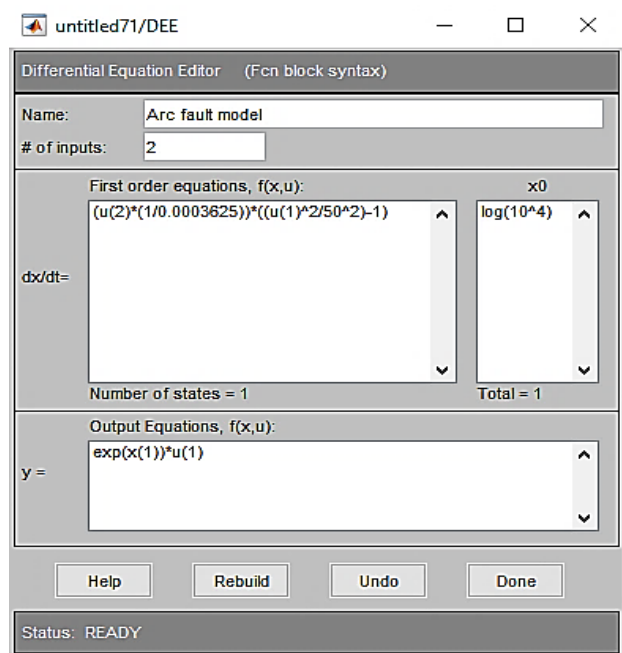

Fig. 2: The proposed DEE of Mayr arc model in MATLAB.

Fig.5 shows series arc fault and it can be observed from this figure, that when the voltage reached to a certain value (220v), the arc is initiated.

Fig .6 shows the parallel arc current simulation result with high current due to short circuit of load.

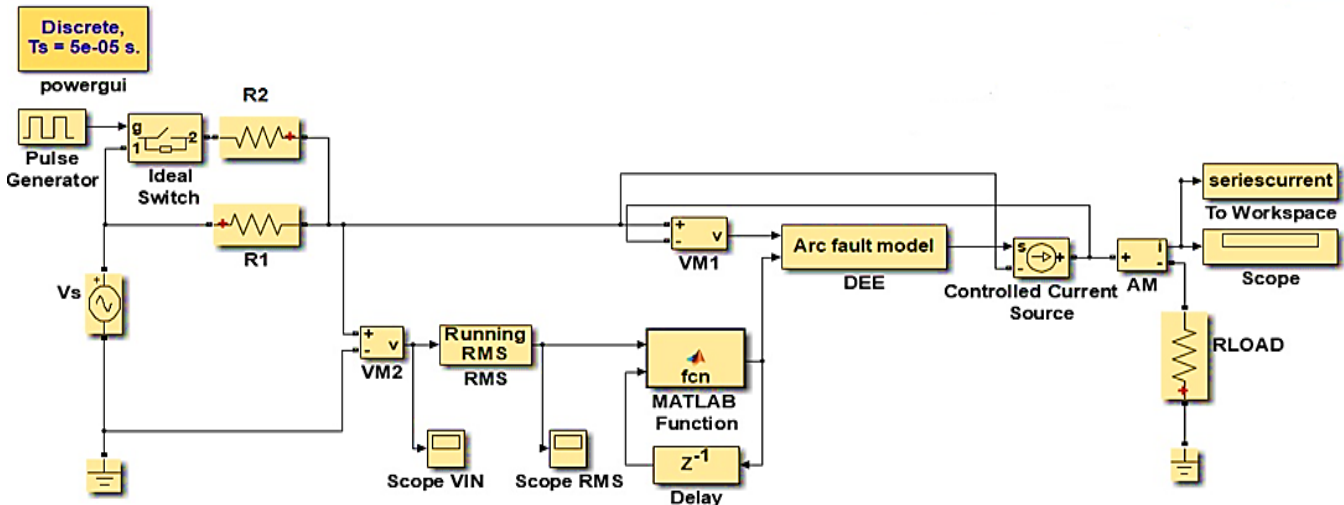

Fig.3: Series arc fault simulation model.

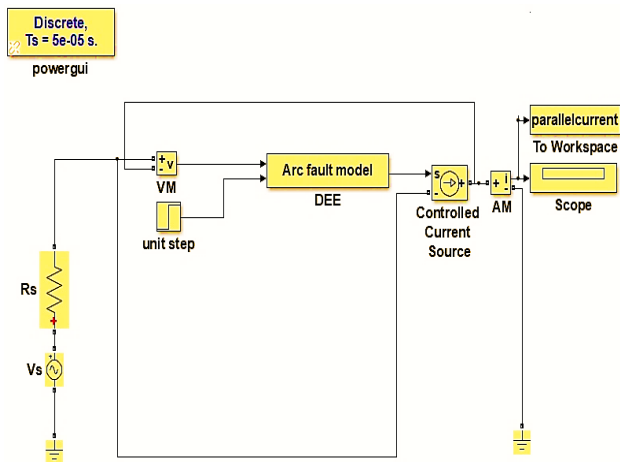

Fig.4: Parallel arc fault simulation model.

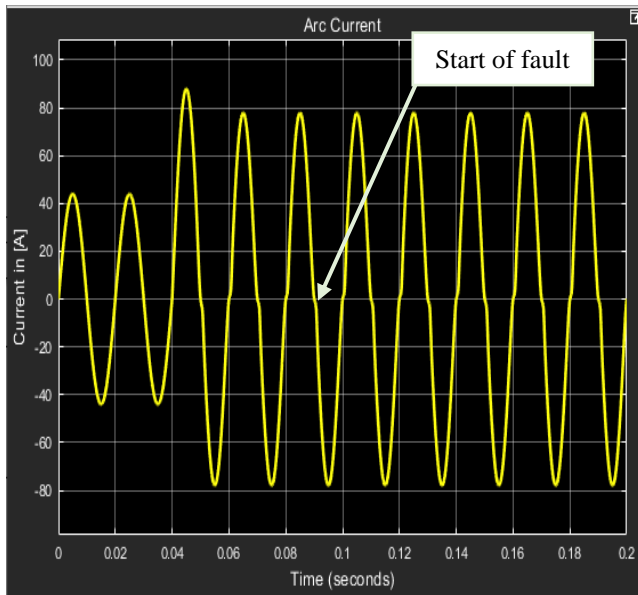

Fig .5: Series arc current waveform.

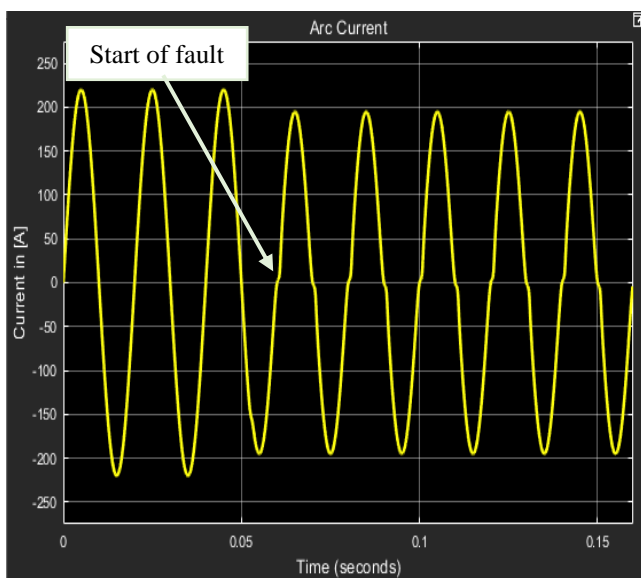

Fig .6: Parallel arc current waveform.

The arc current waveform in these figures of series and parallel arc faults is identical to a sinusoidal signal, but it varies slowly in the zero-current region, which is defined as 'zero-rest' and is also known as (flat shoulders) as shown in Fig.5 and 6. In the time shown above, the output current is extremely near to zero; it falls before reaching a value of over-zero, but changes slowly until it reaches a value of over-zero.

#### IV. CONVENTIONAL FAST FOURIER TRANSFORM METHOD FOR ARC DETERMINING

The Fast Fourier Transform is a mathematical method that transforms data from the time domain into the frequency domain. Simply put, the vertical axis is still amplitude, but it is now measured against frequency rather than time [12].

The Fast Fourier transform (FFT) is a catch-all term for a variety of algorithms. In contrast to the direct measurement of the DFT, they all have a lower computational complexity. The Cooley-Tukey algorithm [13], which decomposes the original DFT into a set of smaller DFTs, is the most widely used FFT algorithm. Two ways of decomposition are decimation-in-frequency (DIF) and decimation-in-time (DIT). They achieve speed, as with all FFTs, by reusing the effects of smaller, intermediary computations to calculate several DFT frequency outputs. The radix-2 Decimation in Time (DIT) FFT algorithm method is used in this case. Radix-2 DIT was selected because of its straightforward and easy-to-implement form.

#### IV. WAVELET DETECTION

The series and parallel When a single-phase series and parallel arc fault happen, the arc voltage and current waveforms show considerable mutation and a large singularity in the fault time. It is capable of extracting fault information from complex transient waveforms and calculating the fault moment. The Fourier transform is a fundamental technique for investigating function singularity. It can only identify the general nature of the singularity due to the lack of spatial localization, making it difficult to estimate the distribution of unique points in space [12], [13]. To circumvent the disadvantages of the Fourier transform, wavelet method is implemented to properly localize the arc moment.

Because the CWT will give a lot of data redundancy by accounting for every conceivable scale and shift step, it turns out that choosing these steps on a dyadic basis will make the analysis more efficient and space-saving [14], [15]. This concept has been used in the discrete wavelet transform (DWT), which is a strong practical filtering approach that allows for a quick wavelet transformation.

Signal analysis applications as seen in a previous subsection may require the low frequency constituents of the signal, other applications may require the high frequency ones. It is for that reason, the conventions approximations and details are usually common to the DWT. Approximations represent the low frequency large scale constituents of the signal, whereas details represent the high frequency small scale signal constituents [14].



The DWT generates signal approximations and details by employing a collection of low and high pass filters. The presence of such a collection of filters is dependent upon the existence of two distinct sorts of functions, namely the scaling function and the wavelet function, both of which are unique to particular types of mother wavelets [14], [15].

The iterative process of analyzing the signal within the set of DWT filters is called the Multi Resolution Analysis (MRA). At the first decomposition stage, the signal enters the low pass filter (LPF) specific to a certain mother wavelet scaling function. The approximation coefficients (CA) will be obtained after the convolution of signal samples with the transfer function coefficients of such a filter and down sampling by 2 [14].

To acquire the signal's detailed coefficients (CD) at the first stage of decomposition, it must be sent through a high-pass FIR filter (HPF) adjusted to the wavelet function, with its samples convolved with the filter transfer function coefficients, and then down sampled by two. At the second decomposition step, the first stage approximation coefficients will be handled identically to the input signal in order to get the second stage approximation and detail coefficients.

## V. IMPLEMENTATION OF WAVELET & FFT TRANSFORMATION IN MODEL

### A. Series And Parallel Arc Fault Wavelet Analysis Simulation Model

To design the series and parallel arc fault circuit with Wavelet analysis it's very important to selecting the best mother wavelet function, having eight cycles and 256 number of samples per cycle means having a sampling time (Ts) of  $\frac{1}{256 \times 50}$  which equals  $7.8125 \times 10^{-5} \text{ sec}$ , the inverse is the sampling frequency (fs) which equals 12.8 kHz. A program routine is written within MATLAB m-file editor environment in order to perform the suitable mother wavelet test. In this test, the wavelets used are the Daubechies of the orders of 2 – 8 [116]. Test results for the system are given in the Table (1), a plot revealing the relation between each mother wavelet function and the average error calculated is shown in Fig.7. It can be seen from the results that the winner is the Db2 mother wavelet due to having the least average error value. This mother wavelet function can then be exploited in analyzing signals to be presented to the decision-making system dedicated for the detection of faults.

Now it's also important to select the number of decomposition level of wavelet analysis. Therefore, if the aspects of signals to be extracted by the DWT can be captured and discriminated at lower decomposition stages, then such stages will be preferred over higher ones, as regard to the selection of the best stage for the analysis, it is found after performing a number of tests that the first

decomposition stage of the Db2 related DWT analysis is as high, accurate, and computationally cost effective as required to distinguish between healthy and faulty series and parallel arc fault system states. And it's found that CD1 in the first level and the rest of the levels is the best detail coefficient to extract the series and parallel arc fault effectively. so, the first level was chosen for the presence of CD1 in it.

TABLE 1  
Results of the Best Mother Wavelet Test

Mother Wavelet	Average Error Value
Db2	1.4634e-08
Db3	1.3081e-07
Db4	2.8235e-08
Db5	4.5494e-08
Db6	2.8010e-08
Db7	3.4447e-08
Db8	6.0712e-08

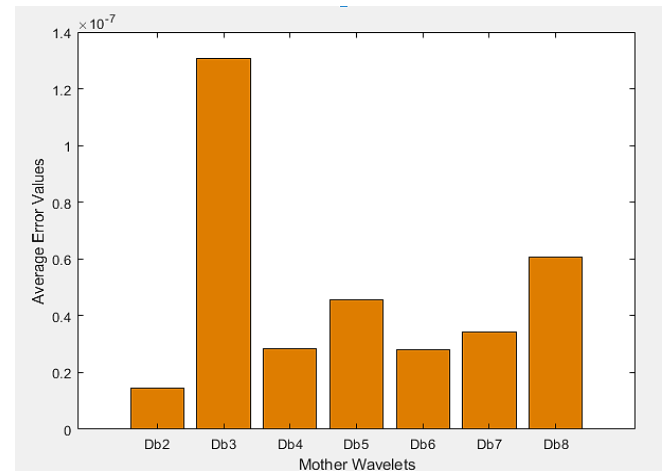

Fig:7. Best mother wavelet test results for the detection scheme dedicated for the simple test system.

The mother wavelet function is Daubechies of order 2 is the best mother wavelet here and the best level is 1. Therefore, this analysis adopts db2 wavelet, analyzes arc voltage and current waveforms in one-dimensional multi scale. It is decomposed the two dimensions; the series arc fault occurs when the voltage supply is reaching to ascertain value. and the parallel arc fault occurs at 0.05sec. where CA1 is the approximate coefficient and the CD1 is the details coefficient 1, the model MATLAB/Simulink of series and parallel arc fault is will be as shown in Fig. 8 and 9.

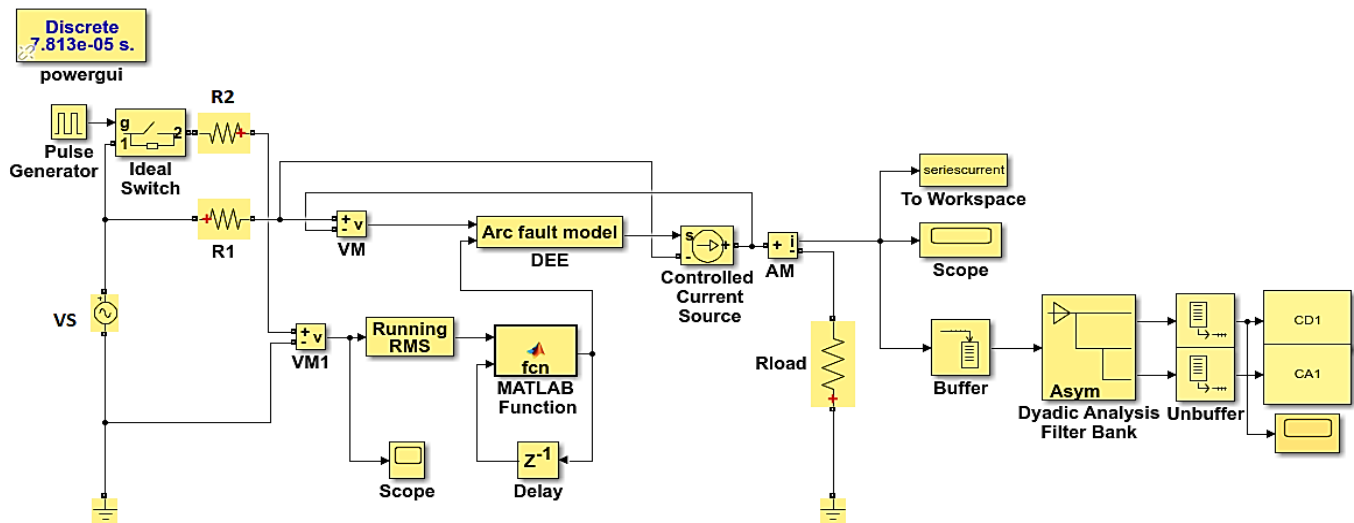

Fig.8: Series arc fault simulation model.

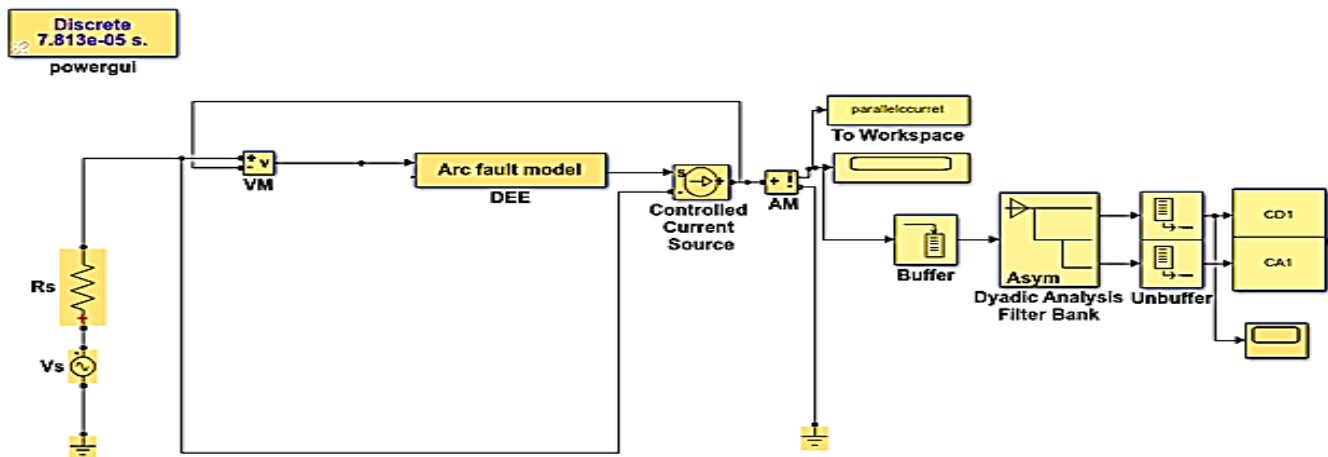

Fig.9: Parallel arc fault simulation model.

The simulation model for series and parallel arc faults is built in MATLAB/Simulink utilizing a dyadic filter bank block in conjunction with a buffer block that conducts frame-based processing from the DSP system toolbox in the Simulink model. This procedure is the Dyadic Filter Bank's Frame-Based Operation. The simulation model with a wavelet detection model of series and parallel arc fault is created in MATLAB/Simulink by employing a dyadic filter bank block to build the wavelet detection online and a buffer block with a buffer size of  $2^n$  where  $n$  is the number of levels. This buffer block does frame-based processing from the model's DSP system toolset. This procedure is the Dyadic filter bank's Frame-Based Operation.

#### B. Series and Parallel Arc Fault FFT Analysis Simulation Model

To simulate the FFT in MTLAB, we use the implemented FFT Both the normal operation current and arc fault current reanalyzed with FFT. MATLAB Simulink online by using buffer is adopted and length of FFT is 64 the radix-2 Decimation in Time (DIT) FFT algorithm method is used in this case. Radix-2. The amount of data that can be processed by Radix-2 is restricted to  $2^n$ [18],[19], it can be seen from the simulation model of series and parallel arc fault. the spectrum analyzer it used to shows the waveforms in the frequency domain. This simulation models are online model by using the implemented buffer tool. The proposed simulation model in MATLAB/Simulink of series and parallel arc fault with FFT technique respectively, are shown in Fig.10 and 11.

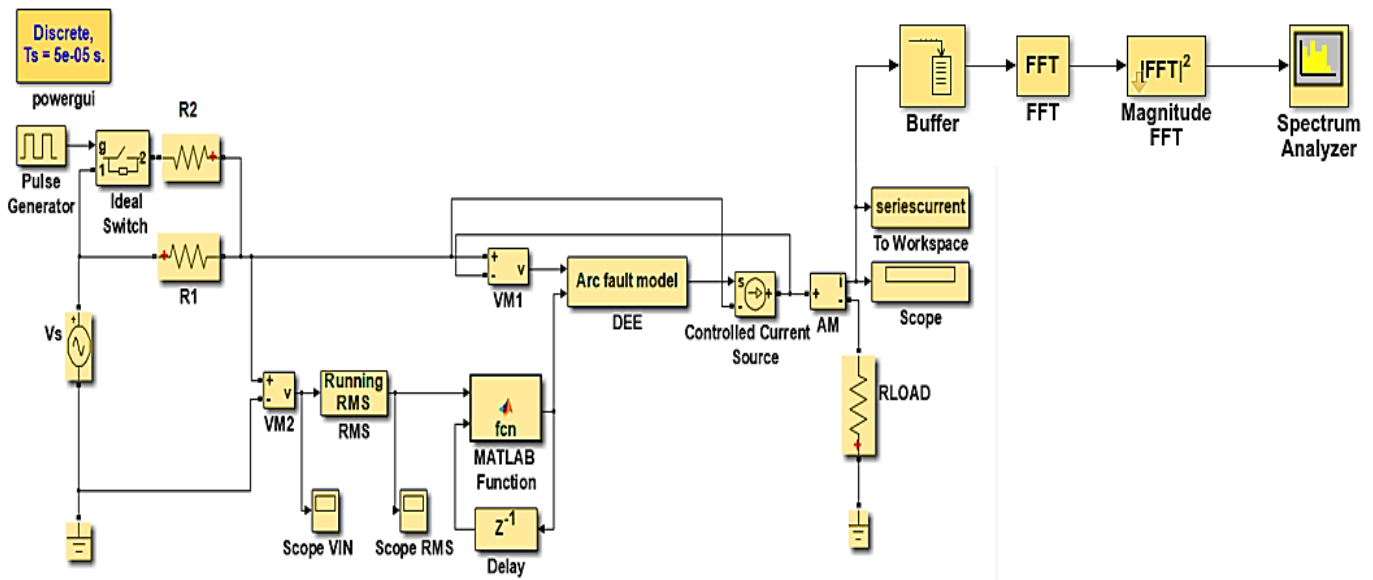

Fig.10: Series arc fault FFT simulation model.

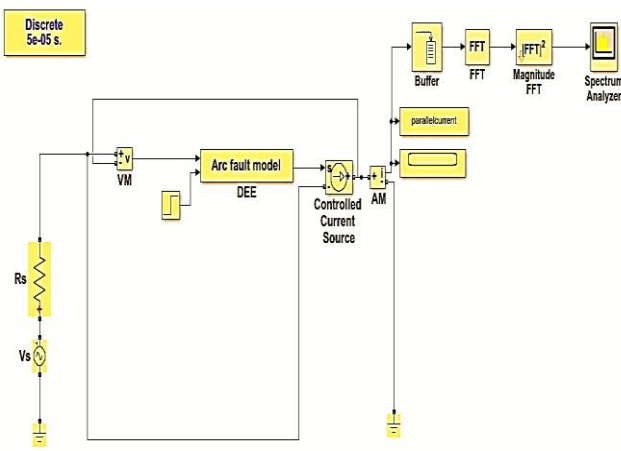

Fig.11: Parallel arc fault FFT simulation model.

### VI. SIMULATION RESULT

This section presents simulation results for wavelet and FFT methods of series and parallel arc fault detection.

#### A. Simulation result with discrete wavelet detection.

The simulation result with wavelet detection model of series and parallel arc fault with MATLAB/Simulink and use dyadic filter bank block to build the wavelet detection. These models are online simulation by using buffer as shown in Fig.8 and 9.

MATLAB/Simulink wavelet transform and simulation results of Arc current waveforms can be used to identify where an arc fault happened. The Daubechies Wavelets are an orthogonal wavelet family with compact support. This enables high-quality extraction of localized signal disruptions (ignoring fundamental components).

By least average of error, Daubechies wavelets db2 were determined to be capable of extracting arc-fault information. The coefficients of the LPF and HPF FIR filters were then determined and utilized in the method. The results of its series and parallel arc fault operations are shown in Fig.12 and 13.

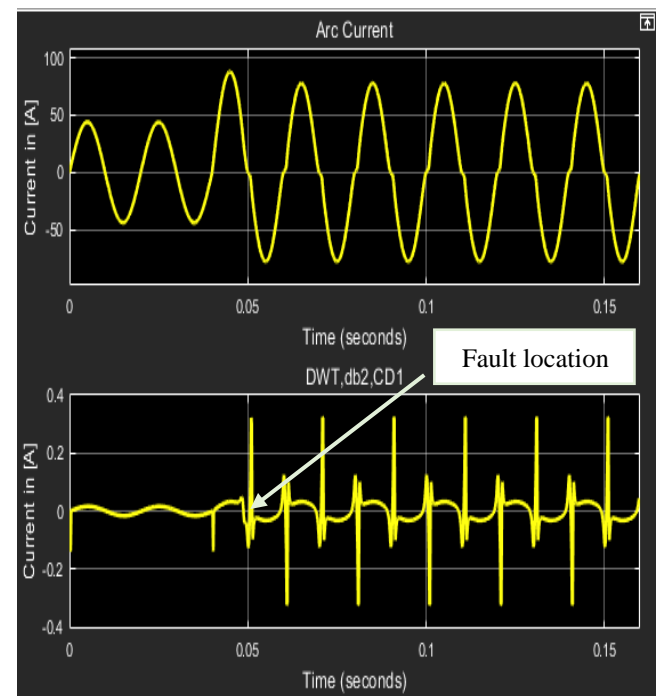

Fig .12: Simulation result of series arc fault using DWT and db2.

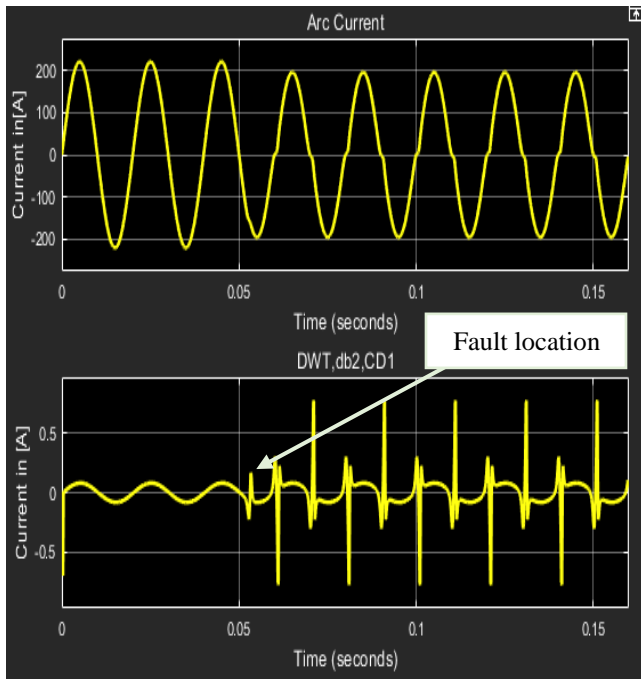

Fig .13: Simulation result of parallel arc fault using DWT and db2.

### B. Simulation result with FFT Analysis

From the proposed simulation model of series and parallel arc fault with FFT analysis implementation in MATLAB/Simulink. The FFT results clearly show that the harmonic amplitude of arc current is low when the circuit is operating normally and when an arc fault happens, the current spectrum's amplitude increases also the numbers of harmonics are increase. This method determines whether or not a certain frequency variable occurs and this knowledge is regardless of where this item occurs in time. This is why Fourier Transformation is ineffective when the signal's frequency varies over time, i.e., when the signal is non-stationary. But to distinguish the arc faults from the healthy signals, we analyzed these signals using FFT and found that these results differ in the amplitude of harmonics of the healthy and arc fault signals. To overcome this drawback of FFT, we preferred DWT, the results of FFT technique of series and parallel arc fault are shown in Figures from Fig.14 to Fig.17.

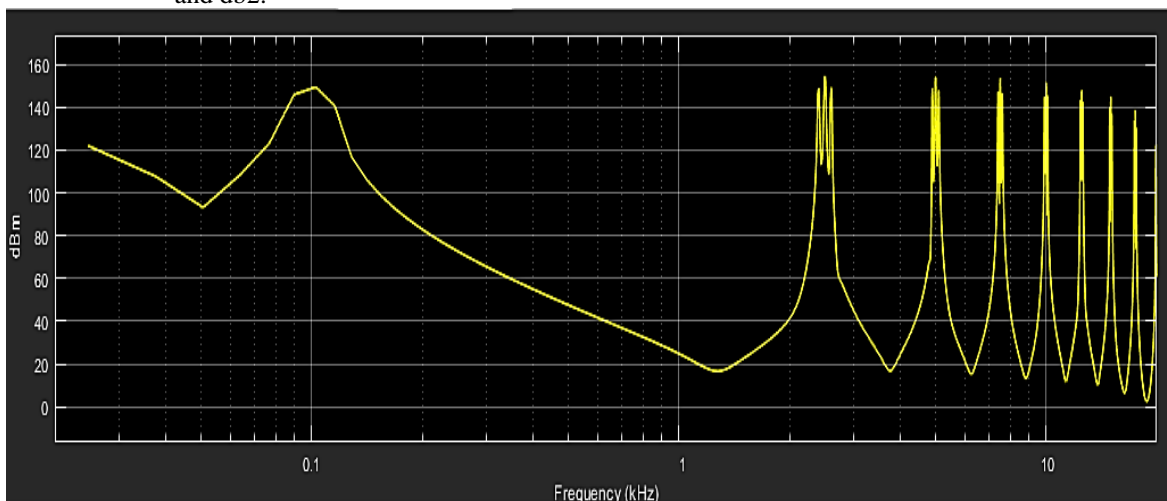

Fig. 14. Series healthy current waveform analyzed online with FFT Simulink

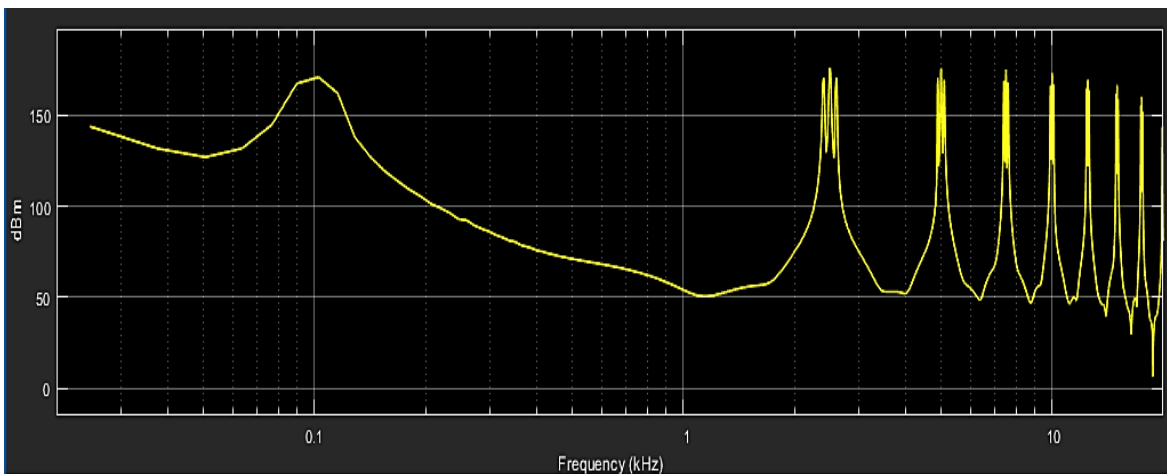

Fig. 15: Parallel healthy current waveform analyzed online with FFT Simulink.



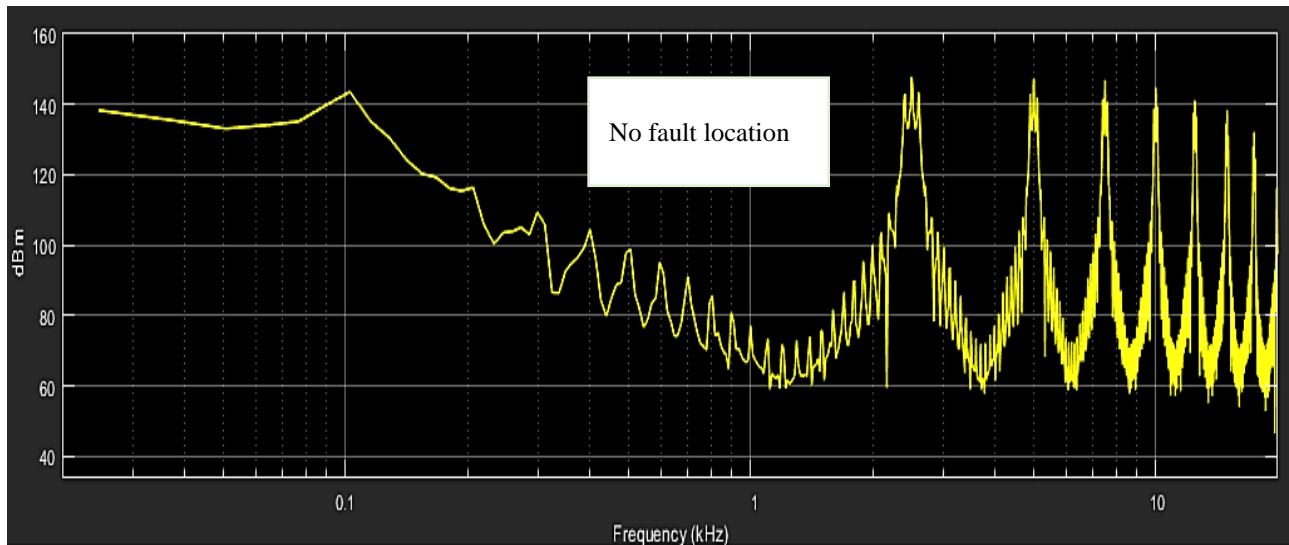

Fig. 16: Series arc current waveform analyzed online with FFT Simulink.

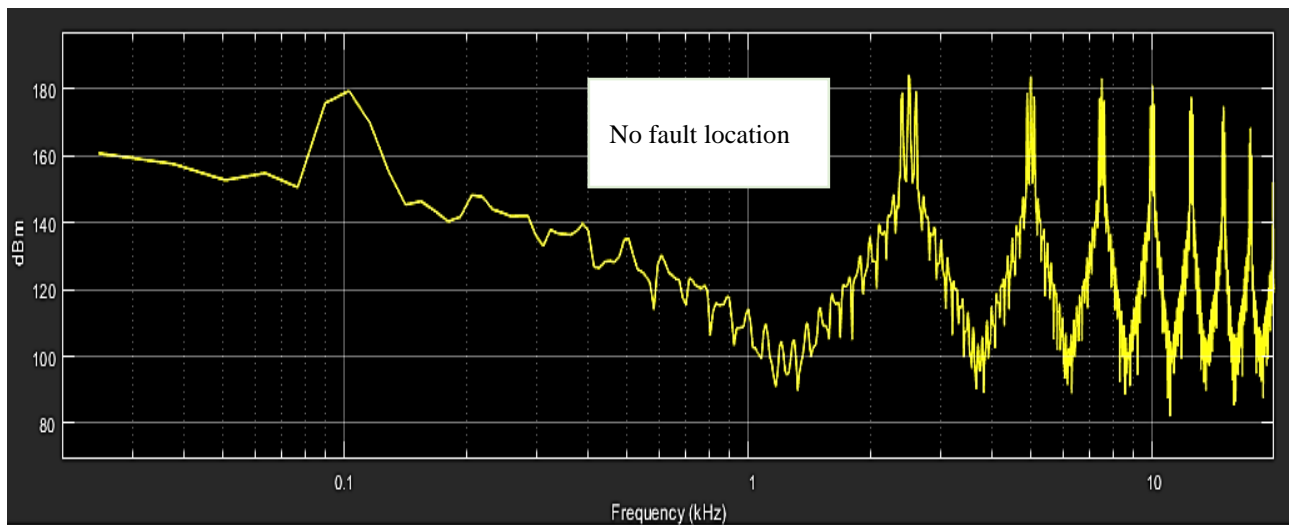

Fig. 17: Parallel arc current waveform analyzed online with FFT Simulink.

TABLE 2  
The Series Fault Design Circuit Modified System Parameters.

Parameter	Value
voltage source	311volt.
Frequency	50Hz
arc length L	2mm
$R_1$	$5\Omega$
$R_2$	$0.00001\Omega$
$R_{LOAD}$	$5\Omega$

TABLE 3  
The Parallel Fault Design Circuit Modified System Parameters.

Parameter	Value
Voltage Source $V_s$	311v
Frequency	50Hz
Source Resistance	$5\Omega$
Start Time of Unit Step	0.05s

## VII. CONCLUSION

The identification of series and parallel arc faults was the subject of this paper. A new MATLAB-based technique for identifying household series and parallel arc faults was provided. The paper proposed a suitable and effective arc

modeling technique. The results demonstrate that this model is capable of accurately reflecting the features of real-world series and parallel arc faults. This paper shows the current and voltage waveforms of arc faults in circuits with purely resistive loads and it was discovered that arc faults have distinct characteristics in their present arc. A discrete wavelet transform of the arc current waveform was used; it is capable of accurately determining the arc fault moment. The frequency responses of the respective filter banks were analyzed for wavelet analysis using the best mother wavelet and appropriate number of levels. After that, the results are utilized to compare the signal's FFT and discrete wavelet techniques. Therefore, the frequency analysis of stationary signals is done with FFT, which uses a fixed window and does not find the moment when the arc starts, and the amplitude harmonic of current is extremely low when the circuit is operating normally, as seen by FFT results. When an arc fault occurs, however, the current spectrum's amplitude rises. The discrete wavelet analysis performs much better than the traditional Fourier transform approach because it provides a flexible time-frequency grid to analyze signals whose spectral content changes over time, and it uses a variable window to locate the time when the arc is initiated.

#### CONFLICT OF INTEREST

The authors have no conflict of relevant interest to this article.

#### REFERENCES

- [1] Fire Safe Europe, FSEU publications, 2019, <https://firesafeeurope.eu/fseupublications/>, online, accessed: 11.05.2019.
- [2] G. D. Gregory and G. W. Scott, "The arc-fault circuit interrupter: an emerging product," in *IEEE Transactions on Industry Applications*, vol. 34, no. 5, pp. 928-933, Sept.-Oct. 1998. doi: 10.1109/28.720431.
- [3] H. Cheng, X. Chen, F. Liu and C. Wang, "Series Arc Fault Detection and Implementation Based on the Short-time Fourier Transform," *2010 Asia-Pacific Power and Energy Engineering Conference*, Chengdu, China, 2010, pp. 1-4. doi: 10.1109/APPEEC.2010.
- [4] M. H. Riza Alvy Syafi'i, E. Prasetyono, M. K. Khafidli, D. O. Anggriawan and A. Tjahjono, "Real Time Series DC Arc Fault Detection Based on Fast Fourier Transform," *2018 International Electronics Symposium on Engineering Technology and Applications (IES-ETA)*, Bali, Indonesia, 2018, pp. 25-30. doi: 10.1109/ELECSYM.2018.8615525.
- [5] M. Naidu, T. J. Schoepf and S. Gopalakrishnan, "Arc fault detection scheme for 42-V automotive DC networks using current shunt," in *IEEE Transactions on Power Electronics*, vol. 21, no. 3, pp. 633-639, May 2006. doi: 10.1109/TPEL.2006.872385.
- [6] N. Zamanan, J. Sykulski, and A. K. Al-Othman, "Arcing high impedance fault detection using real coded genetic algorithm," Japan, Aug. 20–21, 2007, pp. 197–203.
- [7] I. Khan and M. Critchley, "Arc fault detector," 2000, vol. 25, no. 3, pp. 1–4. <http://ebookbrowse.com/arc-fault-detector-paper-pdf-d245318580>.
- [8] J. L. Guardado, S. G. Maximov, E. Melgoza, J. L. Naredo and P. Moreno, "An improved arc model before current zero based on the combined Mayr and Cassie arc models," in *IEEE Transactions on Power Delivery*, vol. 20, no. 1, pp. 138-142, Jan. 2005. doi: 10.1109/TPWRD.2004.837814.
- [9] Q. Yin and R. Ding, "Review of Arc Models in Distribution Networks," *matec web of conferences 61, 02016 (2016)*. doi: 10.1051/MATCE.
- [10] K. Koziy, B. Gou and J. Aslakson, "A Low-Cost Power-Quality Meter with Series Arc-Fault Detection Capability for Smart Grid," in *IEEE Transactions on Power Delivery*, vol. 28, no. 3, pp. 1584-1591, July 2013. doi: 10.1109/TPWRD.2013.2251753.
- [11] R. Yu *et al.*, "Modeling and simulation analysis of single-phase arc grounding fault based on MATLAB," *Proceedings of 2011 International Conference on Electronic & Mechanical Engineering and Information Technology*, Harbin, China, 2011, pp. 4607-4610. doi: 10.1109/EMEIT.2011.6024001.
- [12] ZHANG Zhao-Ning, MAO Peng. "Singularity detection of fault transient signals in power system with wavelet transforms," *Relay*, vol. 28, no. 4, pp. 24-27, 2000.
- [13] J.W. Cooley and J.W. Tukey. An algorithm for the machine calculation of complex Fourier series. *Math. Compute*, Vol. 19, pp. 297–301, April 1965.
- [14] Wavelet Toolbox User's Guide for MATLAB, Version 1, MathWorks 2009.
- [15] I. Daubechies, "The wavelet transforms, time-frequency localization and signal analysis," *IEEE Transactions Information Theory*, vol. 36, no. 5, pp. 961–1005, Sep. 1990.
- [16] Sadiq I. Hassan, Adil A. Obed, and Khalid M. Abdul-Hassan, "Practical implementation for stator faults Protection and diagnosis in 3-ph IM based on WPT and neural network," *The International Journal of Engineering and Science (IJES)*, Vol. 5, 2016, pp. 52-67.
- [17] Michel Misti, Yves Misti, "Georges Oppenheim, and Jean-Michel Poggi, "Wavelet Toolbox," User's Guide, Math Works, July 2004.
- [18] A.V. Oppenheim and R.W. Schaffer. *Discrete-Time Signal Processing*. Prentice Hall, 1989.
- [19] Ramirez, Rober W., "The FFT: Fundamental and Concept", Textronic Inc, Oregon, 1975.