

Modeling and Simulation of Five-Phase Synchronous Reluctance Motor Fed by Five-Phase Inverter

Namariq Abdulameer Ameen*, Ali Kadhim Abdulabbas, Habeeb Jaber Nekad

Electrical Engineering Department, University of Basrah, Basrah, Iraq

Correspondence

*Namariq Abdulameer Ameen
Electrical Engineering Department
University of Basrah, Basrah, Iraq.
Email: nam.almo79@gmail.com

Abstract

Five-phase machine employment in electric drive system is expanding rapidly in many applications due to several advantages that they present when compared with their three-phase complements. Synchronous reluctance machines (SynRM) are considered as a proposed alternative to permanent magnet machine in the automotive industry because the volatilities in the permanent magnet price, and a proposed alternative for induction motor because they have no field excitation windings in the rotor, SynRM rely on high reluctance torque thus no needing for magnetic material in the structure of rotor. This paper presents dynamic simulation of five phase synchronous reluctance motor fed by five phase voltage source inverter based on mathematical modeling. Sinusoidal pulse width modulation (SPWM) technique is used to generate the pulses for inverter. The theory of reference frame has been used to transform five-phase SynRM voltage equations for simplicity and in order to eliminate the angular dependency of the inductances. The torque in terms of phase currents is then attained using the known magnetic co-energy method, then the results obtained are typical.

KEYWORDS: Five phase synchronous reluctance motor, Reluctance torque, PWM inverter and variable-speed drives.

I. INTRODUCTION

The machine that has taken attention of many scientists in the previous several decades and is gaining more attention as a possible alternative to AC induction drive is synchronous reluctance motor, which is considered as a good selection for many variable-speed drive systems [1][2][3]. SynRM is similar to induction motor (IM) in stator structure but it has no rotor field windings [4], and it is cheaper than permanent magnet motors because it has no magnets [5]. There are several advantages for the SynRM, such as simple rugged structure, easy maintenance compared with squirrel cage motors, minor manufacturing cost, high torque per unit volume is viable, a small moment of inertia, it has simple control schemes, minimized losses (no copper losses) and high efficiency due to rotor winding absence [2][6]. If SynRM compared with brushless (BL) motors, it is more robust than BL motors with lower cost rotor structure [7]. The SynRM is structurally simpler with only rotor being salient than doubly salient structure of switched reluctance motor, furthermore it is better than SRM from torque ripple consideration [2][8][9]. SynRM suffer some drawbacks like the poor power factor and low torque density (somewhat acceptable), and can be reduced by control aspect or by take attention of design parameters of SynRM, also the number of phases of SynRM is an effective way to reduce torque ripple when increased [10][11].

Multiphase synchronous reluctance machines considered as an ideal alternative in the propulsion with the advances in modern power electronics. Particularly, five phase machine has attracted much interest in new years [12]. Generally, several advantages of high phase number drives over conventional three phase drives such as upper torque density, better efficiency, greater fault tolerance, amplitude reducing, torque pulsations frequency increasing, rotor harmonic currents reduced, reducing the current per phase without increasing the voltage per phase, decreasing the DC link current harmonics and higher trustworthiness. So, it is possible to increase the torque per rms ampere for equal volume machine by rising the number of phases [2][4][13]. Also, the torque can be more increased without increasing copper losses by the possibility of injecting the third harmonic into five phase machine, while the injection of third harmonic to increase torque is not viable in three phase machines [14], however, it's not our object.

In recent years, multi-phase design for drive system is used in applications where high dependability is required such as electric/hybrid vehicle, ship propulsion, aerospace applications, and high power applications. Consequently, the demand of n separate drive units in multiphase system is not unfair for large drives since numerous of the needed components are obtained in the modern designs [5][15][16].



This is an open access article under the terms of the Creative Commons Attribution License, which permits use, distribution and reproduction in any medium, provided the original work is properly cited.

© 2021 The Authors. Published by Iraqi Journal for Electrical and Electronic Engineering by College of Engineering, University of Basrah.

Figure(1) shows a simple representation model for two-pole five phase SynRM with concentrated winding in stator and rotor of salient pole type which produced by eliminating the cutout from a round rotor. The concentrated windings are the choice in motor building because the Distributed Windings stator (DW) consequences in higher manufacturing costs, caused by distributed winding complexity [17].

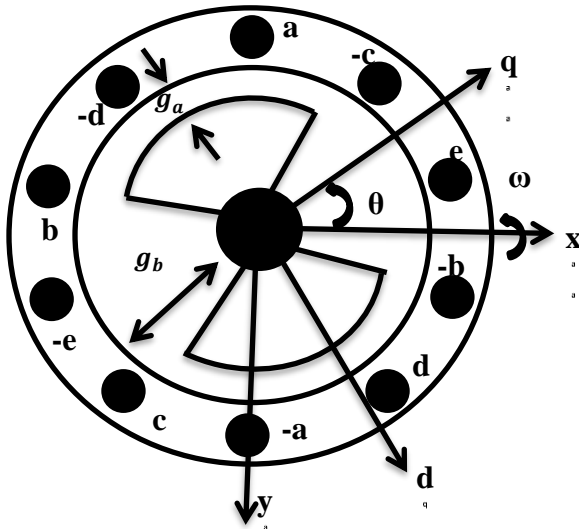

Fig.1.Simple model for a 2-pole, five-phase synchronous reluctance motor

Motor phases are spaced by 72° electrical degree[18]. The minimum air gap length that shown in the figure is g_a and the maximum air gap length is denoted by g_b . Torque density is highly effected by saliency ratio g_b/g_a . In fig.1.there is alignment between the q-axis and the axis of phase windings, the rotor position θ is the angle between stator q-axis and rotor q-axis, notice that the d-axis is considered lag the q-axis by 90° . The SynRMs can be categorized into axially laminated and radially laminated synchronous motors. There are three types of synchronous reluctance rotors, they are the simple salient pole rotor, the transverse laminated rotor, and the axial laminated rotor described in[19]and [20].

In this paper the modeling of five phase synchronous reluctance motor using reference frame theory is represented, and Simulink for drive system(the machine with sinusoidal pulse width modulation (SPWM) technique for voltage source inverter is done) using Matlab simulation program. This paper is organized as follows, section II clarifies the principle of motor operation, section III shows the mathematical modeling of system equations.Section IV and V shows the simulation implementation and experimental results respectively, and finally section VI display the conclusions.

II. THEORY OF OPERATIONS

In order to understand the operating principle of synchronous reluctance motor, let us remember the following basic truth when a part of magnetic material

tending to bring it into the most thick side of the field, it aligned by the force in such a way that magnetic path reluctance spread through the material will be minimum.

In brief, when a part of magnetic material is floating to motion in magnetic field , it will align itself with the field to make magnetic circuit reluctance minimum, all the configurations of synchronous reluctance motor are doing the same working principle, the stator has three-phase or five phase as the motor our object , symmetrical windings, that creates a sinusoidal rotating field in the air gap when energized.The rotor has unexcited ferromagnetic material with polar dropping.

So, SynRM operation principles depends on the reluctance torque, which is relies on the saliency ratio, described as the ratio between the direct axis inductance and the quadrature axis inductance. Principle of operation can be clarified by a simple example. In Fig.2. there are two objects, the first one has anisotropic geometry, but the second has isotropic geometry. The first object has two axis, maximum magnetic conductance in the direct one, and minimum magnetic conductance in the quadrature one. The second object has equal magnetic conductance in every axis. If external magnetic field is applied, the first object try to reduce magnetic circuit resistance causing the force that rotate this object, while the second object stays immovable[21].

When stator windings which are displaced by 72° are excited by five phase inverter, rotating magnetic field which rotates at synchronous speed is produced. Sinusoidally distributed stator winding creates a magnetic field in a synchronous reluctance motor, this field can be considered sinusoidal .

So, there will continuously be a torque attempted to decreasing the entire system potential energy by field distortion reduction along the q- axis. For example, if the

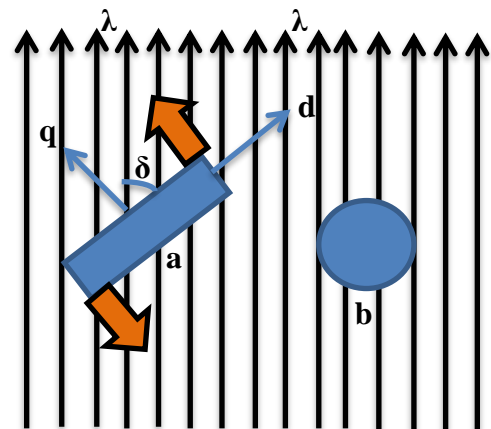

Fig.2.SynRM operating principle(a)object with anisotropic geometry(b)isotropic geometry object

angle δ kept constant by magnetic field controlling, the electromagnetic energy will be always transformed into mechanical energy. Magnetization and torque that attempts to decrease field distortion was created by the stator current,

and this torque is controlled by controlling the current angle which is defined as the angle between stator winding current vector and the rotor d-axis in rotating coordinate system[22].

When the supply is giving to stator winding, reluctance torque on the unsymmetrical rotor is exerted by the revolving magnetic field tending to align the salient pole axis of the rotor with revolving magnetic field axis. [it is minimum reluctance position of magnetic path], so the development of reluctance torque is done by the tendency of ferromagnetic rotor to make alignment with the magnetic field. When the rotor of synchronous reluctance motor is synchronized, the cage winding and stator field rotate synchronously. The machine continues in synchronous operation as the motor is not exceeded the pull-out torque(the load torque required to pull the rotor out of synchronism). The pull-in torque is defined as the maximum load torque which the rotor can come into synchronism with particular load inertia.

The expense of large starting current can be increased by the pull-in torque, but it is still less than the pull-out torque. In adjustable speed multimotor drives requiring exact speed coordinate between motors, the reluctance motor have been widely used

All the motors in multi drive system are operate synchronously at all times if they are accelerated simultaneously from standstill by supply frequency increasing, so without regard to the pull-in torque requirements, they can be designed for optimum synchronous performance. [22]

III. SYSTEM EQUATIONS AND TRANSFORMATION

The dynamic behavior of the motor can be described by the parameter equations such as voltage and torque which is time-varying in nature. Solve of these differential equation is complex, so time varying variables will be changed to time invariant to minimize the motor voltage equations difficulty due to electric circuit relative motion. Iron saturation will assumed to be neglected and only fundamental component of air gap flux will be taken into account.

Under balanced condition, five phase stator voltage of SynRM is expressed as follow:

$$V_a = \sqrt{2} V_{rms} \sin(\omega t) \quad (1)$$

$$V_b = \sqrt{2} V_{rms} \sin(\omega t - \frac{2\pi}{5}) \quad (2)$$

$$V_c = \sqrt{2} V_{rms} \sin(\omega t - \frac{4\pi}{5}) \quad (3)$$

$$V_d = \sqrt{2} V_{rms} \sin(\omega t + \frac{4\pi}{5}) \quad (4)$$

$$V_e = \sqrt{2} V_{rms} \sin(\omega t + \frac{2\pi}{5}) \quad (5)$$

Generally, the equations in natural reference frame, which the electrical behavior of this machine is described in matrix form as follows:[2]

Stator voltage equation:

$$\mathbf{V}_s = \mathbf{R}_s \mathbf{I}_s + \mathbf{p} \boldsymbol{\lambda}_s \quad (6)$$

Stator flux linkage equation:

$$\boldsymbol{\lambda}_s = \mathbf{L}_{ss} \mathbf{I}_s \quad (7)$$

Where $\mathbf{p} = d/dt$ and

$$\mathbf{I}_s = [i_{as} \ i_{bs} \ i_{cs} \ i_{ds} \ i_{es}] \quad (8)$$

$$\mathbf{V}_s = [v_{as} \ v_{bs} \ v_{cs} \ v_{ds} \ v_{es}] \quad (9)$$

$$\boldsymbol{\lambda}_s = [\lambda_{as} \ \lambda_{bs} \ \lambda_{cs} \ \lambda_{ds} \ \lambda_{es}] \quad (10)$$

Also

$\mathbf{R}_s = r_s \mathbf{I}$ where \mathbf{I} is 5 by 5 identity matrix and r_s is the stator resistance of each coil, assuming that all coils are the same.

The stator inductance matrix \mathbf{L}_{ss} is a symmetric 5 by 5 matrix of the form :

$$\mathbf{L}_{ss} = \begin{bmatrix} L_{aa} & L_{ab} & L_{ac} & L_{ad} & L_{ae} \\ L_{ba} & L_{bb} & L_{bc} & L_{bd} & L_{be} \\ L_{ca} & L_{cb} & L_{cc} & L_{cd} & L_{ce} \\ L_{da} & L_{db} & L_{dc} & L_{dd} & L_{de} \\ L_{ea} & L_{eb} & L_{ec} & L_{ed} & L_{ee} \end{bmatrix} \quad (11)$$

Since the inductance matrix \mathbf{L}_{ss} change with the rotor position, so the second term of (6) can be written as

$$\frac{d\boldsymbol{\lambda}_s}{dt} = \mathbf{L}_{ss} \frac{d\mathbf{I}_s}{dt} + \frac{d\mathbf{L}_{ss}}{dt} \mathbf{I}_s \quad (12)$$

By using the chain rule, the second term in above equation can be written as

$$\frac{d\mathbf{L}_{ss}}{dt} \mathbf{I}_s = \frac{d\mathbf{L}_{ss}}{d\theta_{rm}} \frac{d\theta_{rm}}{dt} \mathbf{I}_s \quad (13)$$

θ_{rm} is rotor mechanical position, so the rotor mechanical speed is

$$\omega_{rm} = \frac{d\theta_{rm}}{dt} \quad (14)$$

So,

$$\frac{d\mathbf{L}_{ss}}{dt} \mathbf{I}_s = \omega_{rm} \frac{d\mathbf{L}_{ss}}{d\theta_{rm}} \mathbf{I}_s \quad (15)$$

Equation (12) can be written in the form

$$\frac{d\boldsymbol{\lambda}_s}{dt} = \mathbf{L}_{ss} \frac{d\mathbf{I}_s}{dt} + \omega_{rm} \frac{d\mathbf{L}_{ss}}{d\theta_{rm}} \mathbf{I}_s \quad (16)$$

By substituting (15) in (6) yields the voltage equation in the natural frame of reference abcde- system.

$$\mathbf{V}_s = \mathbf{R}_s \mathbf{I}_s + \mathbf{L}_{ss} \frac{d\mathbf{I}_s}{dt} + \omega_{rm} \frac{d\mathbf{L}_{ss}}{d\theta_{rm}} \mathbf{I}_s \quad (17)$$

The set of equation formerly developed describe both the transient and steady-state behavior of a five phase synchronous reluctance machine. Due to the coupling degree between windings, these equation are rather complicated, so it is suitable to represent the machine with easiest set of equations. If space harmonics are ignored, there are well known transformations that can simplify the equations. The inductance matrix \mathbf{L}_{ss} varies with rotor position, because of the salient structure of the rotor.

In order to remove the inductance dependency, a proposed 5 by 5 transformation matrix $\mathbf{T}(\theta)$ is suggested to facilitate the windings inductance matrix and to transform the variables from stationary (a-b-c-d-e) reference frame to a rotating (d-q-x-y-n) reference frame. [2] [8]

That is

$$\mathbf{F}_{dqxy} = \mathbf{T}(\theta) \mathbf{F}_{abcde} \quad (18)$$

Where \mathbf{F} can be \mathbf{V}_s or \mathbf{I}_s

So, the proposed transformation matrix is as follow:

$$T(\theta) = \begin{bmatrix} \cos \theta & \cos(\theta - \frac{2\pi}{5}) & \cos(\theta - \frac{4\pi}{5}) & \cos(\theta + \frac{4\pi}{5}) & \cos(\theta + \frac{2\pi}{5}) \\ \sin \theta & \sin(\theta - \frac{2\pi}{5}) & \sin(\theta - \frac{4\pi}{5}) & \sin(\theta + \frac{4\pi}{5}) & \sin(\theta + \frac{2\pi}{5}) \\ \frac{2}{5} & \cos \frac{2\pi}{5} & \cos \frac{4\pi}{5} & \cos \frac{4\pi}{5} & \cos \frac{2\pi}{5} \\ 0 & \sin \frac{2\pi}{5} & \sin \frac{4\pi}{5} & -\sin \frac{4\pi}{5} & -\sin \frac{2\pi}{5} \\ \frac{1}{\sqrt{2}} & \frac{1}{\sqrt{2}} & \frac{1}{\sqrt{2}} & \frac{1}{\sqrt{2}} & \frac{1}{\sqrt{2}} \end{bmatrix} \quad (19)$$

By applying the transformation in (19) to five phase voltage equations given in (6) can get the voltage equations in term of flux linkages in synchronous rotating reference frame (d-g-x-y-n) as follows

$$\begin{aligned} V_{qs} &= r_s i_{qs} + \omega \lambda_{ds} + \frac{d\lambda_{qs}}{dt} \\ V_{ds} &= r_s i_{ds} - \omega \lambda_{qs} + \frac{d\lambda_{ds}}{dt} \\ V_{xs} &= r_s i_{xs} + \frac{d\lambda_{xs}}{dt} \\ V_{ys} &= r_s i_{ys} + \frac{d\lambda_{ys}}{dt} \\ V_{ns} &= r_s i_{ns} + \frac{d\lambda_{ns}}{dt} \end{aligned} \quad (20)$$

Figure(3) shows the equivalent circuits for the five phase reluctance machine, note that x-axis, y-axis, and n-axis equivalent circuits are all zero equivalent circuits and don't take part in torque production while q-axis and d-axis equivalent circuits are responsible for establishing torque and the magnetizing flux, removing of the dependency of the inductance on rotor position can be done successfully by using the transformation in (19), also control algorithm development to control this five phase SynRM is not very complicated because there is no coupling between the q-axis and the d-axis equivalent circuits[5].

The electrical torque is obtained from the magnetic co-energy W_{co} theory

$$T_e = \left(\frac{\partial W_{co}}{\partial \theta_r} \right) \quad (21)$$

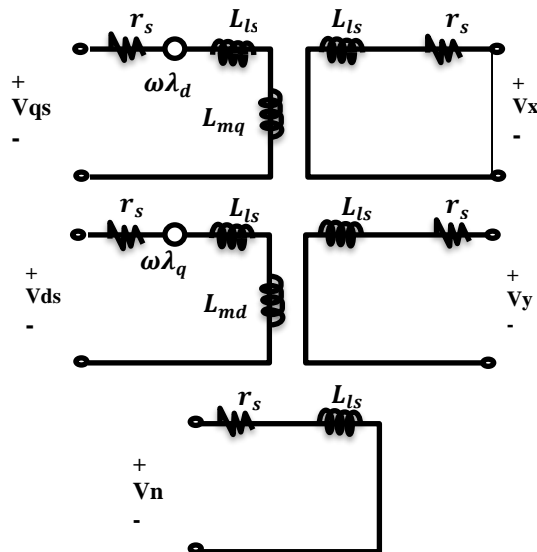

Fig.3 Equivalent circuit for five phase SynRM in the synchronous reference frame[5]

In linear magnetic system, the co-energy is equal to the stored magnetic energy

$$W_{co} = \frac{1}{2} I_s^t [L_{ss}] I_s \quad (22)$$

, and $T_e = \frac{P_{in} P}{\omega \cdot 2}$

$$P_{in} = \frac{5}{2} (L_{md} - L_{mq}) \omega i_{qs} i_{ds} \quad (23)$$

Where P_{in} is the input power

P is the number of poles

ω_m is the mechanical angular velocity

$$\therefore T_e = \frac{5 P}{2 \cdot 2} (\lambda_{ds} i_{qs} - \lambda_{qs} i_{ds}) \quad (24)$$

$$= \frac{5 P}{2 \cdot 2} (L_{md1} - L_{mq1}) i_{qs1} i_{ds1}$$

$$T_e = J \frac{d\omega_m}{dt} + F \omega_m + T_L \quad (25)$$

$$\therefore \omega_m = \frac{1}{J} \int (T_e - F \omega_m - T_L) \quad (26)$$

It's clear from torque equation to observe that the torque is great only if the saliency ratio $\frac{L_d}{L_q}$ is large, so this saliency ratio has to be large and the difference $(L_d - L_q)$ has also to be high value in order to raise the torque density and to improve the efficiency of synchronous reluctance motor. However, this ratio has a physical limit with such structure, the synchronous inductance is maximum value of L_d and the stator leakage inductance is L_q .

Figure(4) shows a five phase inverter that can be used to generate the five phase voltages to supply five phase SynRM by means of pulse-width modulation(PWM) technique as shown in fig.5, there are five legs with five phase supply, each leg has two switch with antiparallel diodes across each switch. The gating signal(pulse generated for switches) advanced or delayed by 72° .

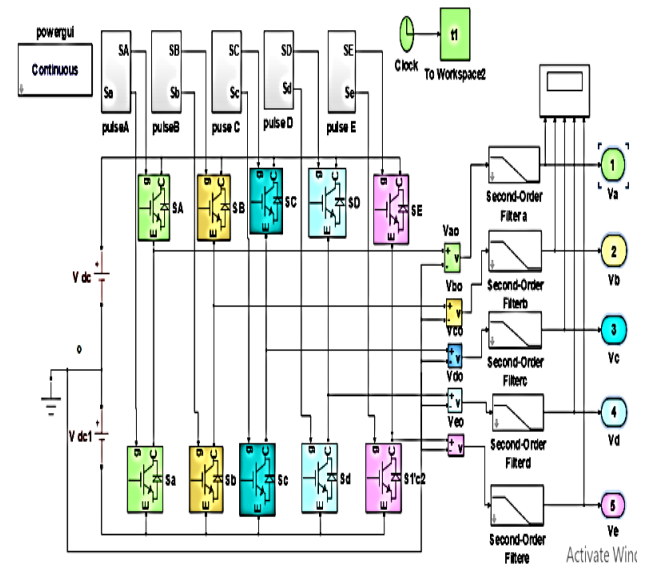

Fig.4 Five-phase voltage source inverter

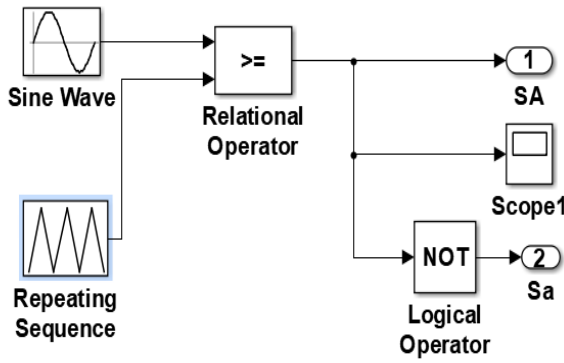

Fig.5. Phase pulse generation subsystem

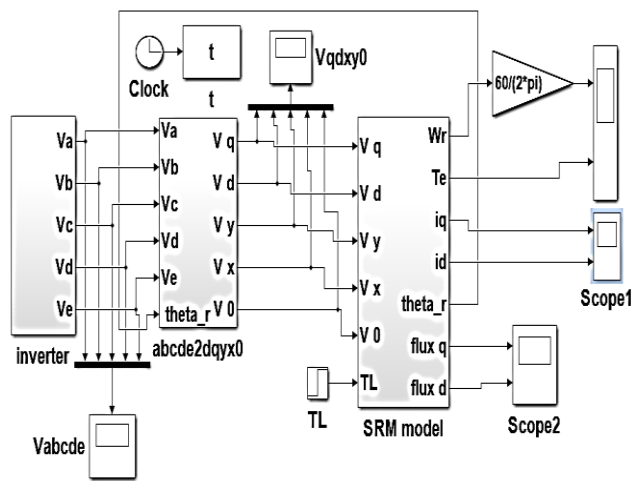
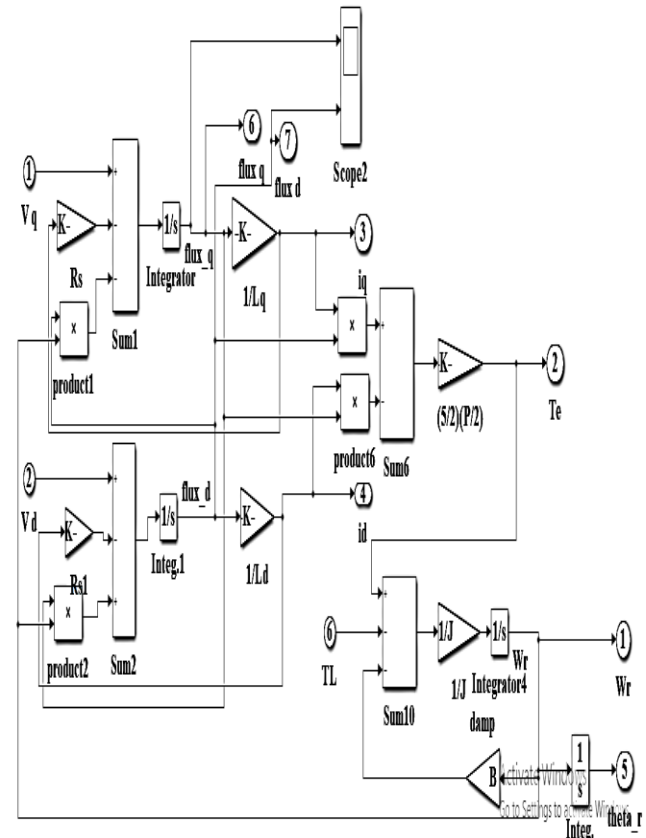

Fig.6. Simulink block of five-phase SynRM motor fed by five-phase inverter

IV. MATLAB/SIMULINK IMPLIMENTATION

Matlab simulation implementation of five phase synchronous reluctance motor model where the voltage, flux, torque equations and transformation matrices are used in Fig.6. It is assumed that the spatial distribution of all the magneto-motive forces (fields) in the machine is sinusoidal, since only torque production due to the 1st harmonic of the field is considered. The motor is fed by five-phase sinusoidal voltage from five- phase voltage source inverter supply. The five phase stator voltages to two phase (d- and q-axis) voltage conversion is done by park transformation sub-blocks , this blocks gives stator currents and fluxes in direct and quadrature axis. Current-flux to torque-speed blocks gives motor speed and torque using equations (24)and(25), sub-system contents as shown in fig.7.The internal structure simulation of five phase synchronous reluctance motor run under no-load and load conditions.

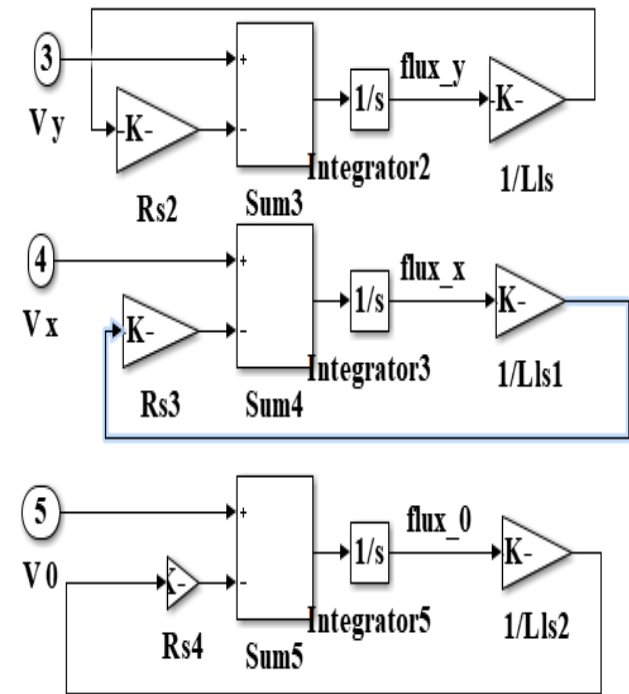

Fig.7. Five-phase SynRM motor simulation model blocks

The mathematical model of the motor is implemented in MATLAB/Simulink and designed for machine have the the parameters used foe modeling are given in table I.

TTABLE I
MACHINE PARAMETERS[23]

Parameters	Description	Values
Ld	d-axis inductance	1.2 H
Lq	q-axis inductance	0.1 H
Vrated	Rated phase Voltage	415 V
Rs	Stator resistance	4
J	Inertia	0.125 Kg.m ²
F	Damping	0.009
P	Number of Poles	4
N rated	Rated speed	1500 r.p.m
f	Frequency	50 Hz
fs	Switching frequency	5 kHz

V. EXPERIMENTAL RESULTS

A. Electromagnetic Torque

During starting the variation in electromagnetic torque with balanced phase currents is noted which happens due to weighty inrush current, then the value of torque will oscillate continuously even at steady state . After a few cycles (about 0.9sec.) steady state torque is achieved with 1.4 N.m, as shown in fig.9, notice that electromagnetic torque value is applicably increased due to five-phase usage rather than three-phase.

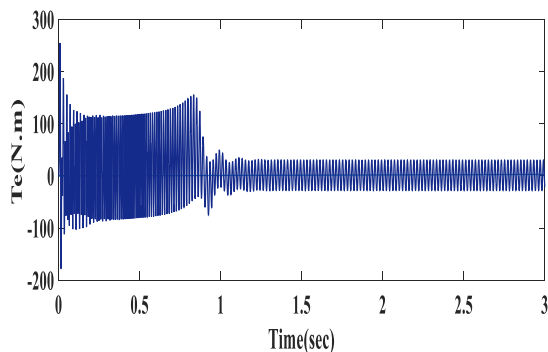

Fig.8. Electromagnetic torque

B. Motor Speed In R.P.M

Small overshoot in speed response is observed at starting as shown in fig.10, until it running at steady state condition at 1500 r.p.m synchronous speed at the time of 0.9 sec. , and it remains constant even with changing in the load torque, i.e. when increasing or decreasing the torque immediately, a little oscillation observed due to the effect of torque oscillation, this can be processed by control method that will discussed in next paper.

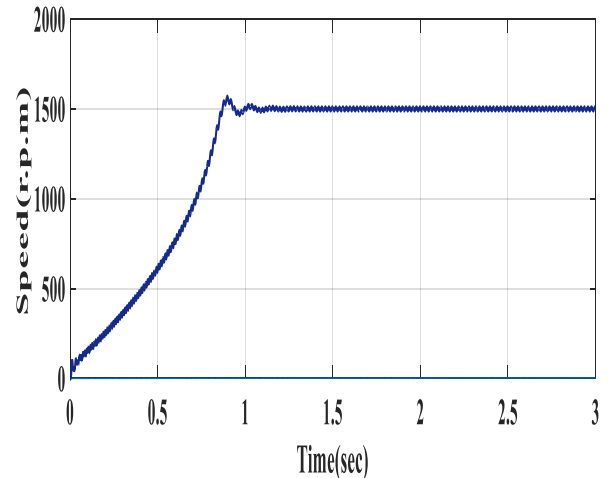

Fig.9. SynRM speed in r.p.m

Torque-speed characteristic is obtain for number of load torque(with values under rated torque) as described, the synchronous speed still unchanged with torque load variation as observed in fig.10

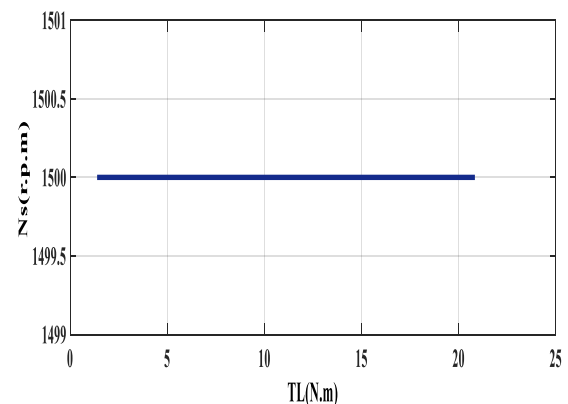

Fig.10. Torque-speed characteristics

The magnitude of o/p inverter voltage depends on modulation index which is defined as, “the ratio V_a/V_C is called Modulation Index (Ma)” and it controls the harmonic content of the output voltage waveform, its prefer for modulation to be larger (i.e the modulation index value near one).[24][25]

$$\text{Modulation index}(Ma) = \frac{\text{Amplitude of sinusoidal signal } Va}{\text{Amplitude of triangular signal } Vc}$$

The variation of electric torque with modulation index is described as shown in fig.11

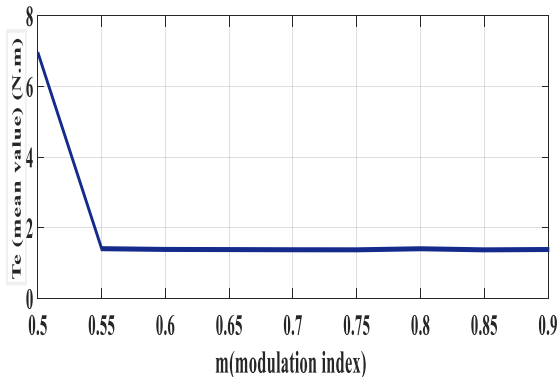

Fig.11. Electric torque variation with modulation index

C. Quadrature And Direct Axis Flux

The quadrature axis flux λ_q will fluctuate sinusoidally from zero sec. till 0.9 sec. at high value, then its value drops to zero (decreasing in magnitude) according to quadrature axis current, while direct axis flux λ_d starting from low value then its value raised in sinusoidal variation after 0.9 sec. time to approximately 0.98 wb as shown in fig.12. (a) and (b). As the losses, and saturation are not considered in designing this model, so the fluxes and the currents are oscillating in nature.

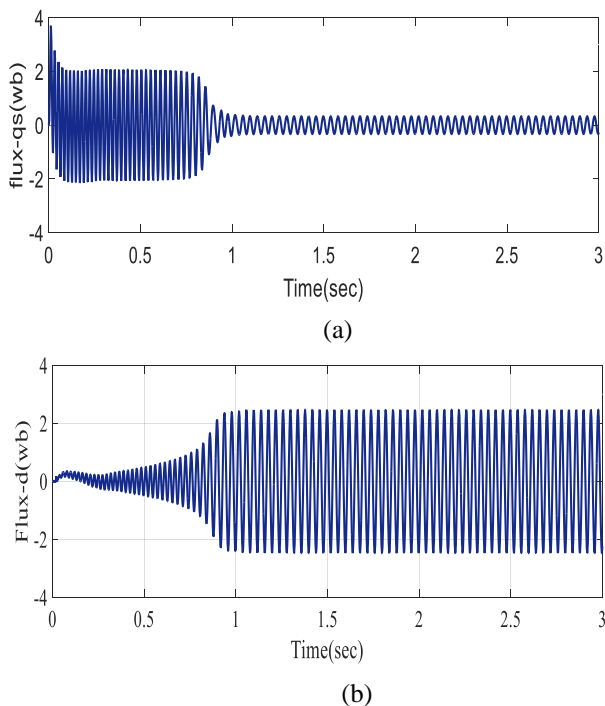

Fig.12.(a) Quadrature axis flux(b)Direct axis flux

VI. CONCLUSIONS

This paper establishes the mathematical models of five phase synchronous reluctance motor fed with five phase voltage source PWM inverter. The examination in the area of multiphase machines mention that it is applicable to use phase number higher than three phase in machines. Multiphase machines technology has many preferences, such as high reliability as machines run continuously even if one of its many phases is open or short circuited with not much deprivation in performance, lower current per phase which is beneficial feature especially in electric vehicle and similar applications. For simplifying machine equations, park transformation is done from stationary reference frame ABCDE to rotating reference frame dqsyn. The current, flux, torque and speed waveforms are observed under no load and on load condition, the modulation index is accounted under several values of modulation signals amplitude, the curve of modulation index with torque is observed, and torque-speed characteristic is drawn, so all the results was typical.

The model can be implemented for higher number phases using transformation matrices for n-phase machine, so this paper will be helpful for all those who are recent into the area of multiphase motor drive in universal and five phase synchronous reluctance motor in special.

CONFLICT OF INTEREST

The authors have no conflict of relevant interest to this article.

REFERENCES

- [1] H. A. Toliyat, S. P. Waikar, and T. A. Lipo, "Analysis and simulation of five-phase synchronous reluctance machines including third harmonic of air gap MMF," *IEEE Transactions on Industry Applications*, vol. 34, no. 2, pp. 332-339, 1998.
- [2] R. Shi, H. A. Toliyat, and A. El-Antably, "A DSP-based direct torque control of five-phase synchronous reluctance motor drive," *APEC 2001. Sixteenth Annual IEEE Applied Power Electronics Conference and Exposition*, pp. 1077-1082, 2001.
- [3] R. Shi, H. A. Toliyat, and A. El-Antably, "Field oriented control of five-phase synchronous reluctance motor drive with flexible 3rd harmonic current injection for high specific torque," *IEEE Industry Applications Conference. 36th IAS Annual Meeting, Chicago, IL*, pp. 2097-2103, 2001.
- [4] S. M. Ismaeel, S. M. Allam, E. M. Rasheed, "Current vector control techniques of five phase synchronous reluctance motor," *International Middle East Power Systems Conference (MEPCON), Cairo, Egypt*, pp. 1180-1185, 2019.

- [5] R. Shi and H. A. Toliyat, "Vector control of five-phase synchronous reluctance motor with space vector pulse width modulation (SVPWM) for minimum switching losses," *APEC. Seventeenth Annual IEEE Applied Power Electronics Conference and Exposition, Dallas, TX, USA*, vol. 1, pp. 57-63, 2002.
- [6] S. J. Mun, Y. H. Cho, & J. H. Lee, "Optimum design of synchronous reluctance motors based on torque/volume using finite-element method and sequential unconstrained minimization technique," *IEEE Transactions on Magnetics*, vol. 44, no. 11, pp. 4143-4146, 2008.
- [7] T. J. E. Miller, *Brushless Permanent-Magnet and reluctance motor drives*, 2nd ed, Oxford university press, New York, 1989.
- [8] H. A. Toliyat, R. Shi, and H. Xu, "A DSP-based vector control of five phase synchronous reluctance motor," *IEEE Industry Applications Conference, Thirty-Fifth IAS Annual Meeting and World Conference on Industrial Applications of Electrical Energy, Rome, Italy*, vol. 3, no. 3, pp. 1759-1765, 2000.
- [9] B. Bilgin, J. w. Jiang and A. Emadi, *Switched Reluctance Motor Drives: fundamentals to applications*, 1st ed, CRC Press, Taylor and francis group, 2019.
- [10] Q. chen, Y. Yan, G. Xu and M. Xu, "Principle of Torque Ripple Reduction in Synchronous Reluctance Motors With Shifted Asymmetrical Poles," *IEEE Journal of Emerging and Selected Topics in Power Electronics*, vol. 8, no. 3, 2020.
- [11] Q. Chen, X. Shi, G. Xu and W. Zhao, "Torque calculation of five-phase synchronous reluctance motors with shifted-asymmetrical-salient-poles under saturation condition," *CES Transactions on Electrical Machines and Systems, IEEE*, vol. 4, no. 2, 2020.
- [12] A. Iqbal, "Dynamic performance of a vector-controlled five-phase synchronous reluctance motor drive: an experimental investigation," *IET Electric Power Applications*, vol. 2, no. 2, pp. 298-305, 2008.
- [13] A. Iqbal, E. Levi, M. Jones and Mohibullah, "Simulation studies of current regulated PWM VSI fed multi-phase AC machine drives," *Proceedings Student Conference on Research and Development, Putrajaya, Malaysia, SCORED*, pp. 390-394, 2003.
- [14] H. A. Toliyat, L. Xu and T. A. Lipo, "A five phase reluctance motor, with high specific torque," *IEEE Transactions on Industry Applications*, vol. 28, no. 3, pp. 659-665, 1992.
- [15] A. K. M. Arafat & S. Choi, "Optimal phase advance under fault-tolerant control of a five-phase permanent magnet assisted synchronous reluctance motor," *IEEE Transactions on Industrial Electronics*, vol. 65, no. 4, pp. 2915-2924, 2017.
- [16] S. S. R. Bonthu, S. Choi, J. Baek, "Comparisons of three-phase and five-phase permanent magnet assisted synchronous reluctance motor," *IET Electric Power Applications*, vol. 10, no. 5, pp. 5- 2016.
- [17] V. Bilyi, D. Bilyi, O. Moros, G. Dajaku and D. Gerling, "Synchronous reluctance Machine with multiphase stator cage winding," *20th International Conference on Electrical Machines and Systems (ICEMS), Sydney, NSW, Australia*, 2017.
- [18] H. Abu-Rub, A. Iqbal & J. Guzinski, *High performance control of AC drives with MATLAB/Simulink models*, 1st ed., John Wiley & Sons, 2012.
- [19] J. Kolehmainen, "Synchronous Reluctance Motor With Form Blocked Rotor," *IEEE Transactions on Energy Conversion*, vol. 25, no. 2, pp. 450-456, 2010.
- [20] M. Nagrial, J. Rizk & A. Hellany, "Analysis and performance of high efficiency synchronous reluctance machines," *International journal of energy and environment*, vol. 2, no. 2, pp. 247-254, 2011.
- [21] R. Moghaddam, *Synchronous reluctance machine (SynRM) in variable speed drives (VSD) applications*, Doctoral dissertation, 2011.
- [22] R. Moghaddam, *Synchronous reluctance machine (SynRM) design*, Royal Institute of Technology, Stockholm, Sweden, 2007.
- [23] G. Pellegrino, N. Bianchi, *The rediscovery of Synchronous Reluctance and Ferrite Permanent Magnet motors*, 1st ed, Springer, Press 2016.
- [24] A. O. Abdali, A. K. Abdulabbas, H. J. Nekad, "Nonconventional diode clamped multilevel inverter with reduced number of switches", *Iraqi Journal for Electrical and Electronic Engineering*, vol.16, no.2, pp.21-32,2020.
- [25] E. Cipriano and E. Roberto, *Advanced Power Electronics Converters: Pwm converters processing AC voltages*, 1st ed, IEEE, Press, Willy, 2015.