

Design and Analysis of a Single-Band Printed Rectenna Circuit at WiFi Frequency for Microwave Power Transmission

Ahmad A. Salih

 Electrical Engineering Department
 University of Basrah
 Basrah-Iraq

ahmed.kadhemi301@gmail.com

Transmission

Abdulkareem S. Abdullah

 Electrical Engineering Department
 University of Basrah
 Basrah-Iraq

drasabdallah@ieee.org

ABSTRACT: In this paper, a single-band printed rectenna of size (45×36) mm² has been designed and analyzed to work at WiFi frequency of 2.4 GHz for wireless power transmission. The antenna part of this rectenna has the shape of question mark patch along with an inverted L-shape resonator and printed on FR4 substrate. The rectifier part of this rectenna is also printed on FR4 substrate and consisted of impedance matching network, AC-to-DC conversion circuit and a DC filter. The design and simulation results of this rectenna have been done with the help of CST 2018 and ADS 2017 software packages. The maximum conversion efficiency obtained by this rectenna is found as 57.141% at an input power of 2 dBm and a load of 900 Ω .

Index Terms—Rectenna, HSMS-282B Schottky diode, microwave power transmission, conversion efficiency, patch antenna

I. INTRODUCTION

Nowadays, with the development in semiconductors, the wireless electronic devices are used widely because they need small power and most of them are powered by batteries that result in some disadvantages. For example, large size and weight devices with continual maintenance due to the batteries limited life time cost more than devices that work with very difficult environmental conditions. Therefore, the technique of ambient power harvesting is suggested as a solution. A rectenna used to convert the microwave power to direct current (DC) power [1,2] is a rectifying antenna consisted of an antenna and a nonlinear rectifying element (Schottky diode, IMPATT diode...etc.) and operates without an internal power source. The schematic diagram of a rectenna is shown in Fig.1. Working frequency is very important in the design of rectenna, and is selected according to the application used. Received power by an antenna at a certain distance from the emitter decreases with

the increase of frequency. The amount of available power (P_r) at a certain distance from the emitter is given by Friis equation [3,4].

$$P_r = P_t \cdot G_t \cdot G_r \cdot \left(\frac{\lambda}{4\pi R} \right)^2 \quad (1)$$

where P_t is the transmitter power, G_t and G_r are the transmitter and receiver antenna gains, respectively, λ is the wavelength used and R is the distance separating the transmitter and the receiver.

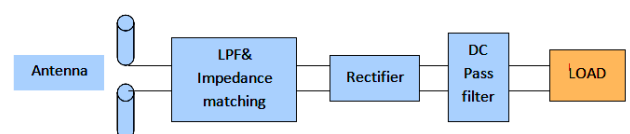

Fig.1: Block diagram of a rectenna

The rectenna was invented in 1964 and patented in 1969 [5] by US electrical engineer W. C. Brown, who demonstrated it with a model helicopter powered by microwaves transmitted

from the ground, received by an attached rectenna. Since the 1970s, one of the major motivations for rectenna research has been to develop a receiving antenna for proposed solar power satellites, which would harvest energy from sunlight in space with solar cells and beam it down to earth as microwaves to huge rectenna arrays [6]. Two rectenna circuits had been designed at 2.45 GHz and 35 GHz in [7], and the obtained efficiencies were found as 85% at an input power level of 1.2 W and 29% at an input power of 120mW, respectively. A compact rectenna circuit has been proposed in [8] that has the ability to produce an output voltage of 50 V, which is proper for driving mechanical actuators. The circuit has double rectenna elements for increasing output voltage. A miniature circularly polarized rectenna was designed in [9] to work with a frequency of 5.5 GHz, which reduce out of band harmonic emission with the help of integrated band-reject filter. The rectenna has a conversion efficiency of 74% with more than 50 dB out-of-band harmonic suppression at 11 GHz. A rectenna using a compact circularly polarized patch antenna with RF-to-DC power conversion part at 2.45 GHz was proposed in [10]. The adopted antenna built on a low cost FR4 substrate has measured bandwidth of 137 MHz as well as 30 MHz CP bandwidth (3 dB axial ratio). The RF-to-DC conversion efficiency has reached a value of 75% with 1 K Ω resistor load. In [11], a compact reconfigurable rectenna has been designed for wireless power transmission to work at frequencies of 5.2 GHz and 5.8 GHz. The simulated efficiencies were calculated as 70.5% and 69.4% when the input power is 16.5 dBm. In [12], circularly polarized rectenna with harmonic suppression and rectenna array for wireless power transfer were designed to work at a frequency of 5.8 GHz. The designed receiving antenna has a bandwidth of 31.8%. A quartz clock with integrated wireless energy harvesting and sensing functions has been designed in [13]. A simple rectifier is designed to directly match with the clock antenna and rectify the power captured

by the clock. The maximum obtained efficiency is found as 65% at frequency bands of (1.4-1.5) GHz and (1.9-2.1) GHz.

In this paper, a single-band printed rectenna that works at WiFi frequency of 2.4 GHz is intended to be designed and analyzed using Computer Simulation Technology (CST) software package [14] and Advance Design System (ADS) software package [15]. Section II provides the design procedure of the antenna part of this rectenna. Section III presents the necessary steps to design the rectifier part of this rectenna. Section IV provides the conclusion that is extracted by the performance of this rectenna.

II. ANTENNA DESIGN

Antenna is an important part of a rectenna since it is responsible for receiving microwave power from signals. The proposed antenna is in the form of a monopole with a question mark shape patch as shown in Fig.2. It also has an inverted L-shape resonator connected with the ground, and it is used to obtain the required resonant frequency of 2.4 GHz. FR4 is chosen as the substrate to design this antenna with dielectric constant of $\epsilon_r = 4.4$, thickness $h = 1.6$ mm and loss tangent of 0.004.

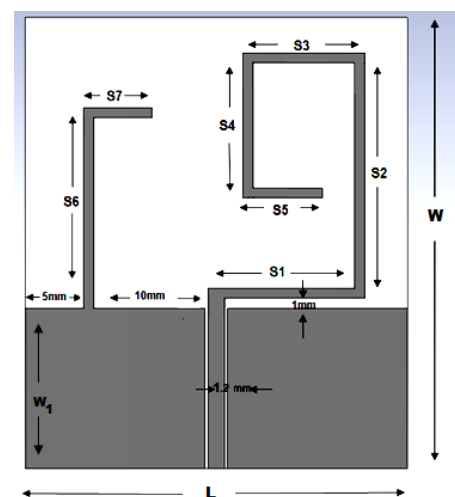

Fig 2: Single-band printed question mark patch antenna

A parametric study has been done to obtain the optimum dimensions of the question mark patch and inverted-L resonator (S1, S2, S3, S4, S5, S6, and S7). These optimum dimensions are given in Table I and they help in obtaining a required value of reflection coefficient that is less than -20 dB.

TABLE I

The optimum design dimensions of the single-band printed question mark patch antenna

Ground plane size ($W_1 \times L$)	$16 \times 36 \text{ mm}^2$
Substrate size ($W \times L$)	$45 \times 36 \text{ mm}^2$
Feed line	$17 \times 1.6 \text{ mm}^2$
Conductor thickness	0.035mm (Copper)
S1	$13.8 \times 1 \text{ mm}^2$
S 2	$23.5 \times 1 \text{ mm}^2$
S3	$11.5 \times 1 \text{ mm}^2$
S4	$14 \times 1 \text{ mm}^2$
S 5	$7 \times 1 \text{ mm}^2$
S 6	$19 \times 1 \text{ mm}^2$
S7	$6.5 \times 1 \text{ mm}^2$

Performance analyses should be done to assure that the antenna is satisfying the required responses at the desired frequency of 2.4 GHz. It includes obtaining the VSWR, reflection coefficient, bandwidth, radiation patterns, gain and directivity.

1. VSWR

To transmit a maximum energy from transmitter to the antenna by the feeder line, the feeder line must be matched to the antenna. To achieve this, the range of VSWR must be between

1 and 2 at the designed frequency of antenna [16]. Fig.3 shows the response of VSWR against frequency. It is found that a value of 1.1703 is obtained at 2.4 GHz, which is good enough to create a matching between the antenna and the feeder line at the designed frequency.

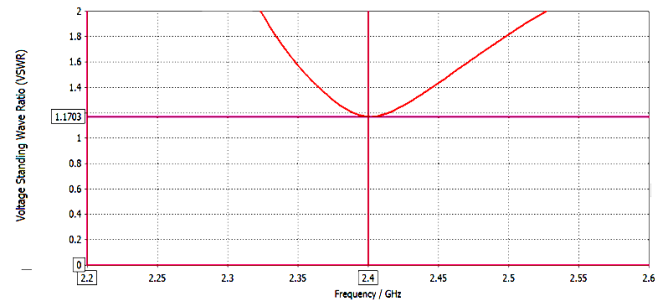

Fig. 3: VSWR vs. frequency of the single-band printed question mark patch antenna

2. Reflection Coefficient

Reflection coefficient represents the power reflected back to the source divided by the power transmitted from the source. By calculating the reflection coefficient, it is possible to determine the loss of the power when transmitting from a transmitter to an antenna [17]. Fig.4 shows the values of the reflection coefficient (in dB) w.r.t. frequency. It is found that a value of -22.146 dB is obtained at the designed frequency of 2.4 GHz. This value indicates that a 99.14 % of the power is transmitted by the antenna and only 0.6% of the power is reflected back to the source.

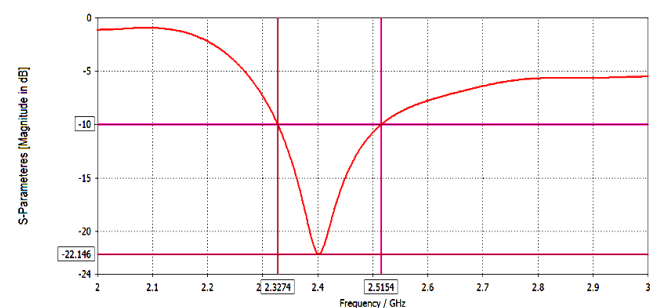

Fig.4: Reflection coefficient vs. frequency of the single-band printed question mark patch antenna.

4. Gain

The antenna gain values against frequency are shown in Fig.5. A value of 0.47076 dB is found at the designed frequency of 2.4 GHz.

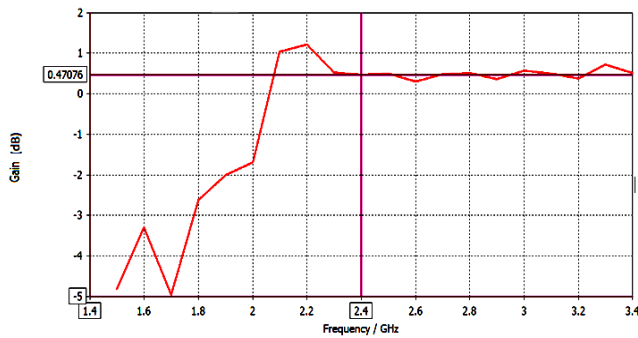

Fig.5: Gain vs. frequency of the single-band printed question mark patch antenna

5. Radiation pattern

The E-plane radiation pattern of the single-band printed question mark patch antenna at 2.4 GHz is shown in Fig.6 . The direction of the main lobe is found at $\theta = 187^\circ$ and the HPBW= 266.5° .

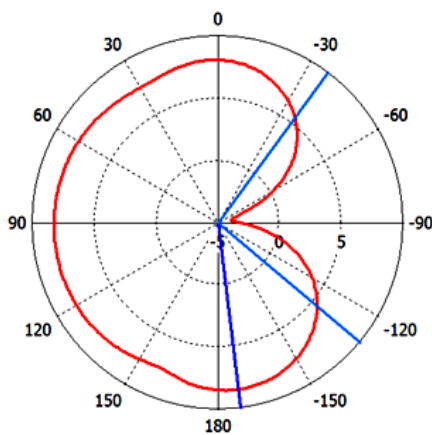

Fig.6: E-plane pattern of the single-band printed question mark patch antenna at 2.4 GHz.

The H-plane of the single-band printed question mark patch antenna at 2.4 GHz is shown in Fig.7.

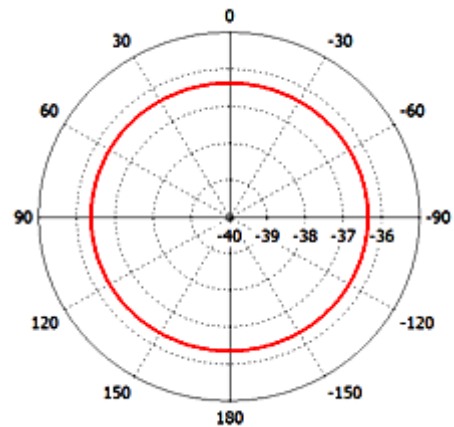

Fig.7: H-plane pattern of the single-band printed question mark patch antenna at 2.4 GHz.

II. RECTIFIER CIRCUIT DESIGN

The overall structure of the classical single-band rectenna is designed by ADS software package and it works at a frequency 2.4 GHz as shown in Fig.8. The antenna designed in the CST software program is replaced by an equivalent power source. A rectifier consists of an impedance matching network (IMN) to provide peak power transfer from the receiving antenna to AC - to - DC conversion circuit and a harmonic filter. The AC - to - DC circuit converts the AC signal received by the antenna to DC signal. The DC filter makes the DC signal smoother to deliver to the load. The RF signal is rectified by using Schottky diode (HSMS-282B), which has specifications shown in Table II.

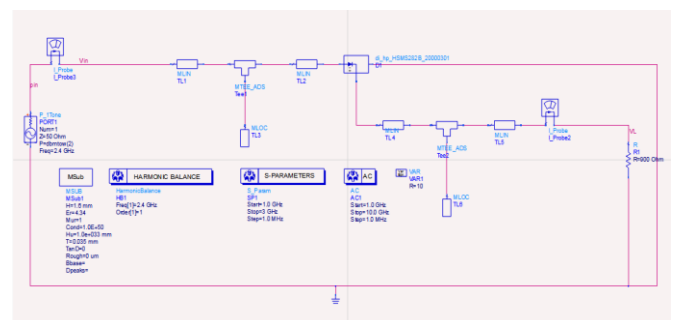

Fig 8: Schematic of the rectifying circuit

TABLE II

Spice parameters of Schottky diode (HSMS-282B)

Parameter	Symbol	Value
Minimum break down voltage	(V_{BR})	15 V
Maximum forward voltage	(V_F)	340 mV
Maximum forward voltage maximum forward current	(V_F) (I_F)	0.5 V 10 mA
Maximum reverse leakage current maximum reverse leakage voltage	(I_R) (V_R)	100 nA 1.0 V
Maximum capacitance	(C_T)	1.0 pF
Typical dynamic resistance	(R_0)	12 Ω

The impedance matching network has a simple shape and designed as a microstrip line of FR4 material from which the antenna was made as shown in Fig.9. It is composed of three lines (T1, T2, and T3) and one T- junction (Tee1). The optimum dimensions of these lines are obtained via parametric study and tabulated in Table III.

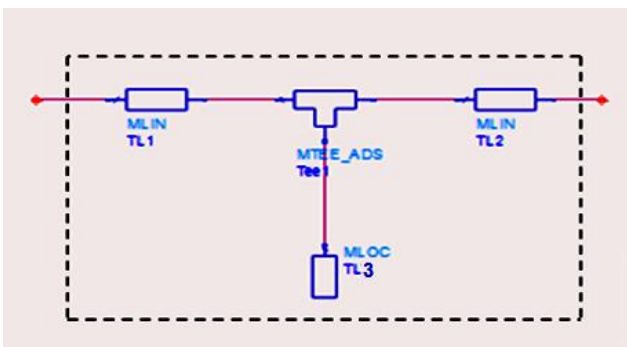

Fig.9: The printed impedance matching network

TABLE III

Optimum dimensions of rectifier circuit

Component Name	Value	Component Name	Value
TL1	(2X3)mm	TL2	(3x5)mm
TL3	(2X14.6)mm	TL4	(2X3)mm
TL5	(3.5X2)mm	TL 6	(2X21.07)mm
Tee1	(2X2X2)mm	Tee2	(2X2X2)mm
R=900 Ω			

The TL4, TL5, TL6 and Tee2 represent the DC filter as shown Fig.10. It is used for smoothing the output DC signal of Schottky diode. The optimum values for TL4, TL5, TL6 and Tee2 have been obtained via parametric study and tabulated also in Table III. The designed DC filter cannot be replaced by any other DC filter in this circuit because this will lead to a change of the frequency response for S_{11} .

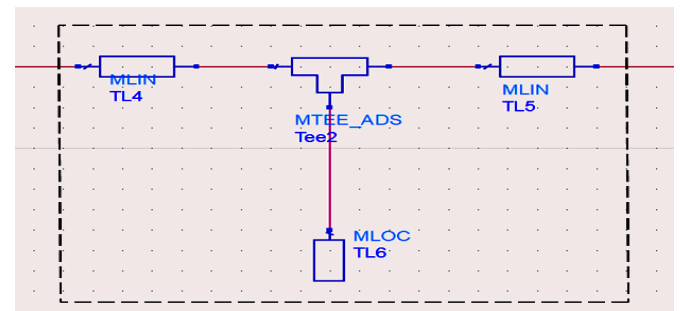

Fig.10: The printed DC filter

The reflection coefficient of the rectifier circuit is found as -41.02 dB at 2.4GHz, which means that a quite good matching is performed at the operation frequency as shown in Fig.11.

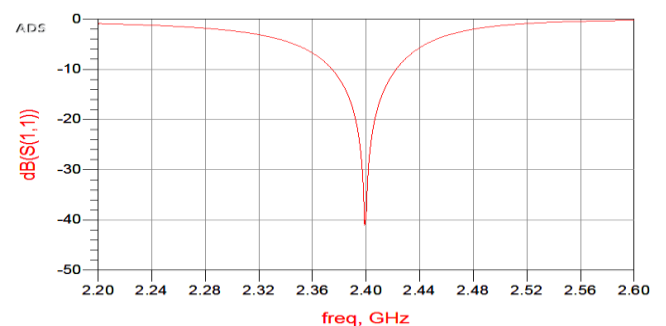

Fig.11: Reflection coefficient vs. frequency of the single-band rectifier circuit

Simulated conversion efficiency at 2.4 GHz as a function of input power for different load resistances of 500 Ω , 700 Ω , 900 Ω , 1200 Ω and 1400 Ω is depicted in Fig.12. It shows that the conversion efficiency of rectifier circuit is less than 50 % at low input powers (less than -10 dBm). An increase of input power leads to

increasing the conversion efficiency of rectifier circuit to a maximum value at 2 dBm of input power. If the input power is increased more than 2dBm, the conversion efficiency is degraded because the Schottky diode voltage has exceeded the breakdown voltage .When the input power is equal to 23 dBm or more , this causes a damage for the Schottky diode.

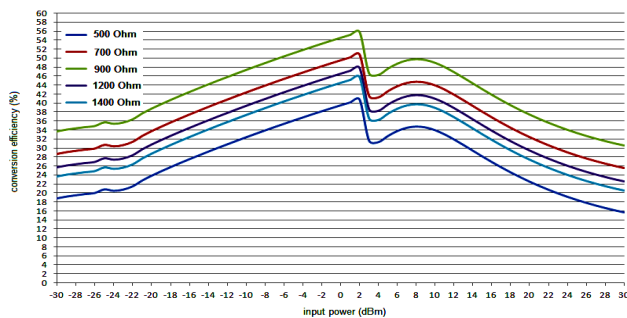

Fig.12: Simulated conversion efficiencies vs. input power of rectifier circuit at 2.4 GHz for different load resistances.

The maximum efficiency is found as 57.141% obtained for 900 Ω load when the input power is 2 dBm as shown in Fig.13.

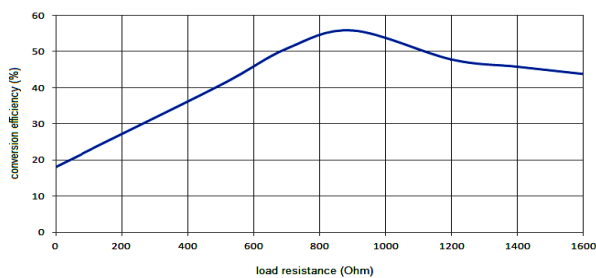

Fig.13: Variation of conversion efficiency of rectifier circuit w.r.t. load resistance at 2.4 GHz with input power of 2 dBm.

III. CONCLUSION

A rectenna is a modern technique for harvesting the microwave energy that is available in ambient. In this paper, a single-band printed rectenna that works at WiFi frequency of 2.4 GHz has been designed and analyzed. The receiving

antenna for the RF signal is composed of a monopole that has the shape of a question mark patch along with an inverted L-shape resonator. The overall dimension of this antenna is $(45 \times 36) \text{ mm}^2$. A simple rectifier circuit that consists of impedance matching network is used to transfer the maximum energy from the receiving antenna to AC-to-DC converter (Schottky diode-HSMS-282B) and DC filter. The maximum conversion efficiency obtained for the rectifier circuits is found as 57.141 % by using a load of 900 Ω and an input power of 2 dBm.

REFERENCES

- [1] S. Kim et al., ‘Ambient RF Energy-Harvesting Technologies for Self-Sustainable Standalone Wireless Sensor Platforms’, Proc. IEEE, vol. 102, no. 11, pp. 1649–1666, Nov. 2014.
- [2] N. Shinohara, Rectennas for microwave power transmission, IEICE Electronics Express, Vol.10, N0.21, pp.1-13 November 2013.
- [3] S. Riviere, F. Alicalapa, A Douyere and D. Lan Sun Luk, A compact rectenna device at low power, Progress In Electromagnetics Research C, vol.16, pp.137-146, 2010.
- [4] Y.-Y. Gao, X.- X. Yang, C. Jiang, and J.-Y. Zhou, A circularly polarized rectenna with low profile for wireless power transmission, Progress In Electromagnetics Research Letters, vol.13, pp.41-49, 2010.
- [5] W. C. Brown, “The History of Power Transmission by Radio Waves,” IEEE Transactions on Microwave Theory and Techniques, Vol. MTT-32, No.9, September 1984.
- [6] K. Wu , D. Choudhury and H . Matsumoto , “Wireless Power Transmission, Technology , and Applications,” IEEE Proceedings, vol.101, no.6, pp.1271-1275, Jun. 2013.
- [7] James O. McSpadden, T. Yoo and K. Chang,” Theoretical and Experimental Investigation of a Rectenna Element for Microwave Power Transmission,” IEEE Transactions on Microwave Theory and Techniques, vol. 40, no.12, pp. 2359-2366, 1992.

- [8] L. W. Epp, A. R. Khan, H. K. Smith and R. P. Smith, "A Compact Dual - Polarized 8.51 GHz Rectenna for High-Voltage (50 V) Actuator Applications," *IEEE Trans. Microwave Theory Tech.*, vol. 48, no. 1, pp. 111-120, (2000).
- [9] M. Ali, G. Yang and R. Dougal, "Miniature Circularly Polarized Rectenna With Reduced Out-of-Band Harmonics," *IEEE Antennas and Wireless Propagation Letters*, vol.5, pp.107-110, 2006.
- [10] T. C. Yo, C. Lee, C. Hsu, C. Luo, "Compact Circularly Polarized Rectenna with unbalanced circular slots," *IEEE Transactions on Antennas and Propagation*, Vol.-56, No. 3, pp. 882 – 886, 2008.
- [11] P. Lu, X. Yang, J. Li, B. Wang, "A compact Reconfigurable Rectenna for Wireless Power Transmission," *IEEE Transactions on Power Electronics*, Vol.30, No.11, pp.6006-6011, 2015.
- [12] Y. Yang, J. Li, L. Li, Y. Liu, B. Zhang, H. Zhu and K. Huang, "A 5.8 GHz Circularly Polarized Rectenna With Harmonic Suppression and Rectenna Array for Wireless Power Transfer," *IEEE Antennas and Wireless Propagation Letters*, Vol.17, No.7, pp.1276-1280, 2018.
- [13] C. Song, A. Yela, Y. Huang, D. S. Vargas, Y. Zhuang, ; Y. Wang, "A Novel Quartz Clock With Integrated Wireless Energy Harvesting and Sensing Functions," *IEEE Transactions on Industrial Electronics*, Vol.66, No.5, pp.4042 – 4053, 2019.
- [14] CST: Computer Simulation Technology Based on FIT Method, 2018.
- [15] ADS: Advanced Design System software, 2017.
- [16] P. Prabhu, C. Poongodi, P. Sarwesh, and Dr. A. Shanmugam, "Design A Low Profile Printed Monopole Antenna for RFID Applications," *International Journal of Innovative Research in Science, Engineering and Technology*, Vol. 2, No. 2, 2013.
- [17] M. Pelosi, M. B. Knudsen, and G. F. Pedersen, "Multiple antenna systems with inherently decoupled radiators," *IEEE Transactions on Antennas and Propagation*, vol. 60, pp. 503-515, 2012.