

Design and Implementation of Locations Matching Algorithm for Multi-Object Recognition and Localization

Abdulmuttalib T. Rashid
 Electrical Engineering Depart.
 Basrah University
 Basrah, Iraq
 abdturky@gmail.com

Wael H. Zayer
 Electronic Department
 Amara Technical institute
 Southern Technical University
 wael_zayer@yahoo.com

Mofeed T. Rashid
 Electrical Engineering Depart.
 Basrah University
 Basrah, Iraq
 Mofeed.t.rashid@ieeee.org

Abstract A new algorithm for multi-object recognition and localization is introduced in this paper. This algorithm deals with objects which have different reflectivity factors and distinguish color with respect to the other objects. Two beacons scan multi-color objects using long distance IR sensors to estimate their absolute locations. These two beacon nodes are placed at two corners of the environment. The recognition of these objects is estimated by matching the locations of each object with respect to the two beacons. A look-up table contains the distances information about different color objects is used to convert the reading of the long distance IR sensor from voltage to distance units. The locations of invisible objects are computed by using absolute locations of invisible objects method. The performance of introduced algorithm is tested with several experimental scenarios that implemented on color objects.

Index Terms— Localization, recognition, look-up table, multi-color objects.

I. INTRODUCTION

The challenges of multi-object recognition and localization represent part of the fundamental problems of intelligent systems. The objects mean either the nodes in wireless sensor networks (WSNs) [1] or the robots in multi-robot systems [2, 3]. A Wireless Sensor Network consists of multi-sensor nodes distributed separately to cooperatively monitor environmental circumstances and has various applications that include traffic monitoring, object tracking, measuring radiation levels from nuclear reactors, navigating ships and volcanic eruptions [4, 5]. Since most of the applications for wireless sensor networks and multi-robot system need to know their initial positions to perform important tasks, a great attention given to the design efficient algorithms for localization. The term localization means that to find the location of objects in an environment [6]. This process is done by manipulating the information received from the sensors and sends it to the infrastructure to compute the location of the objects.

In recent years, in the mobile robots field, the robot localization systems and formation had been of particular interests [7, 8]. The localization of mobile robots is a difficult task due to many physical limitations.

There are two main categories of localization methods: range-based and range-free. Range-based localization approaches used distance or angle measurements among objects in the networks which it is costly method because they are used objects with ranging hardware [9]. Range-free is based on knowledge of proximity to the beacon nodes with knowing positions which greatly depending on the distribution of the anchor nodes and have low accuracy with respect to the range-based localization methods [10].

In terms of computation, multi-object systems are classified into two different architectures; centralized and distributed architectures. The centralized architecture has a beacon node that received data measured by robots and manipulates these data to estimate pose for all robots [11].

Low-cost infrared sensors are used in different tasks like proximity sensing, position control and target recognition. There are several

measurements for the intensity of reflected light by objects depending on the surface type of objects, like surfaces having different colors and different level of reflectivity. Objects features can be determined by these measurements [12-14]. In another work, a study on the effect of glittering and reflective objects with different colors is suggested. This work used the characteristics of output voltage distance of IR sensor, which operates by the principle of single point triangulation. The study experiments on a compact disk and plastic materials with four different colors [15].

This paper aimed to develop a multi-color objects recognition and localization system. The localization system will consist of two beacons with long distance IR sensors to estimate the absolute locations of objects. Each object in the system has different surface color and different reflectivity factor. Object localization and recognition is implemented using locations matching algorithm. The rest of the paper is organized as follows. Section 2 describes the objects locations matching algorithm. Section 3 describes the experimental results. Finally, Section 4 draws the conclusions of the paper.

II. THE LOCATIONS MATCHING ALGORITHM

In this Section, the locations matching algorithm is introduced as a new algorithm for multi-color objects localization. This algorithm recognizes the objects and computes their locations with respect to global beacon nodes. The locations matching algorithm is described in the following subsections.

A. Look-Up Table Construction Algorithm

The look-up table has been constructed which representing the distances between beacon nodes and multi-color objects with respect to reflected voltage. The beacon node contains a sharp long distance IR sensor that operates with the principle of single point triangulation. Each different colored object has a plastic material surface with different reflectivity factor. For example, the white object is chosen with a smoothness surface to produce a highest level of reflectivity to the infrared signal of the long distance IR sensor where the black object is chosen with a coarseness surface to produce a lowest level of

reflectivity. TABLE I is a look-up table used to store the values (output voltages) v_{ij} reading by the long distance IR sensor. Symbol i denotes the number of colored object (number of column in TABLE I) and symbol j denotes the distance between beacon node and colored object (number of row in TABLE I).

TABLE I

The output voltages of long distance IR sensor for different colored objects.

Objects Distances	Colored object 1	Colored object 2	Colored object 3	Colored object 4	Colored object 5	Colored object 6
D_0	V^1_0	V^2_0	V^3_0	V^4_0	V^5_0	V^6_0
D_1	V^1_1	V^2_1	V^3_1	V^4_1	V^5_1	V^6_1
D_2	V^1_2	V^2_2	V^3_2	V^4_2	V^5_2	V^6_2
D_3	V^1_3	V^2_3	V^3_3	V^4_3	V^5_3	V^6_3
D_4	V^1_4	V^2_4	V^3_4	V^4_4	V^5_4	V^6_4
D_5	V^1_5	V^2_5	V^3_5	V^4_5	V^5_5	V^6_5
D_6	V^1_6	V^2_6	V^3_6	V^4_6	V^5_6	V^6_6
D_7	V^1_7	V^2_7	V^3_7	V^4_7	V^5_7	V^6_7
D_8	V^1_8	V^2_8	V^3_8	V^4_8	V^5_8	V^6_8
D_9	V^1_9	V^2_9	V^3_9	V^4_9	V^5_9	V^6_9

B. Distances and Absolute Locations Estimation Algorithm

This subsection describes the basic step to estimate the distances and absolute locations of multi-color objects with respect to global beacon nodes. Each beacon node represents by a long distance IR sensor fixed on a servo motor and placed in one corner of the environment. These beacon nodes scan the environment to estimate the distances and orientations of all visible objects. The output voltage of the long distance IR sensor represents distances and the rotating angle of the servo motor denotes orientations. Since the beacon nodes alone cannot be able to distinguish between colors of the objects so that, each output voltage of the beacon nodes may be indicate different distances for each colored object. These different distances are represented by a matrix of distances and absolute locations for each colored object. Some objects are not visible by the beacon nodes because they are out of sight of these nodes. The following steps perform distances and the absolute locations estimation algorithm:

Step1: Scan the environment with the beacon node 1 to estimate the voltage v_{b1}^i and orientation θ_{b1}^i of each colored object as shown in Fig. 1. The output voltage v_{b1}^i of the beacon node1 represents the distance to the colored object i . The measured voltage v_{b1}^i and orientation θ_{b1}^i of each colored object are stored in matrix A_1 .

$$A_1 = \begin{bmatrix} v_{b1_1} & \theta_{b1_1} \\ v_{b1_2} & \theta_{b1_2} \\ \vdots & \vdots \\ v_{b1_n} & \theta_{b1_n} \end{bmatrix} \quad (1)$$

Where n is the number of the colored objects.

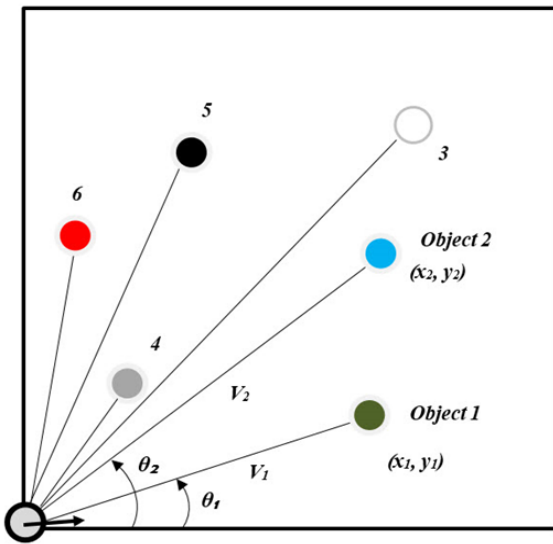

Fig. 1 Measurement the distances and the orientations of the colored objects using beacon node 1.

Step2: Since, the distance represented by the voltage v_{b1}^i in matrix A_1 not has enough information to recognize the colored object i so that we assume that this voltage may be refer to any colored object in TABLE I. For voltage v_{b1}^i in matrix A_1 and with the help of TABLE I we estimate all the possible distances d_{b1}^j from beacon node 1 to all the possible colored objects. TABLE I contains discrete values for distances and voltages of the output characteristic of long distance IR sensor. To obtain the exact distance to any reading not found in this table, we must use the linear interpolation formula as shown in (2) and Fig. 2.

$$x_b = x_a + (v_b - v_a) * (x_c - x_a) / (v_c - v_a). \quad (2)$$

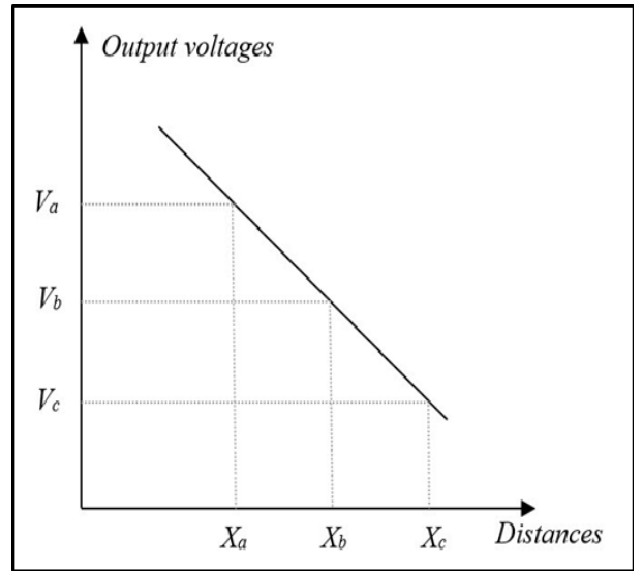

Fig. 2 The linear interpolation.

For example, to find the distance D at voltage V in TABLE I, where the value of voltage V lays between voltages V^1_0 and V^1_1 , we assume according to (2), $V_a = V^1_0$, $V_c = V^1_1$, $D_0 = X_a$, and $D_1 = X_c$. The value of voltage V is computed from (3).

$$D = D_o + (V - V^1_1) * (D_1 - D_o) / (V^1_1 - V^1_0). \quad (3)$$

Where D is the distance X_b in Fig. 2 and V is the voltage V_b .

Step 3: Depending on the location of the beacon node 1 (x_{b1}, y_{b1}), the orientations of colored object i , and the estimated distances in step 2, we can compute the locations for all these possible color objects using (4).

$$\left. \begin{aligned} x_{b1}^i &= x_{b1} + d_{b1}^i \cos \theta_i \\ y_{b1}^i &= y_{b1} + d_{b1}^i \sin \theta_i \end{aligned} \right\} \quad (4)$$

Where (x_{b1}^i, y_{b1}^i) is the possible location j to colored object i with respect to beacon node 1. All the possible distances and locations for each colored object i in matrix A_1 are stored in separated matrix A_{b1}^i which means it contains the information of all possible colored objects for each colored object i in matrix A_1 .

$$A_{b1}^i = \begin{bmatrix} d_{b1}^i & x_{b1}^i & y_{b1}^i \\ d_{b1}^i & x_{b1}^i & y_{b1}^i \\ \vdots & \vdots & \vdots \\ d_{b1}^i & x_{b1}^i & y_{b1}^i \end{bmatrix} \quad (5)$$

Step4: the above steps are repeated for beacon node 2 (see Fig. 3). The measured voltage v_{b2}^i and orientation θ_{b2}^i of each colored object with respect to beacon node 2 are stored in matrix A_2 .

$$A_2 = \begin{bmatrix} v_{b2_1} & \theta_{b2_1} \\ v_{b2_2} & \theta_{b2_2} \\ \vdots & \vdots \\ v_{b2_n} & \theta_{b2_n} \end{bmatrix}. \quad (6)$$

All the possible distances and locations for each colored object i in matrix A_2 are stored in separated matrix A_{b2}^i .

$$A_{b2}^i = \begin{bmatrix} d_{b2}^{i_1} & x_{b2}^{i_1} & y_{b2}^{i_1} \\ d_{b2}^{i_2} & x_{b2}^{i_2} & y_{b2}^{i_2} \\ \vdots & \vdots & \vdots \\ d_{b2}^{i_n} & x_{b2}^{i_n} & y_{b2}^{i_n} \end{bmatrix}. \quad (7)$$

Where (x_{b2}^j, y_{b2}^j) is the possible location j to colored object i with respect to beacon node 2 and d_{b2}^j represent all the possible distances for voltage v_{b2}^j in matrix A_2 from beacon node 2 to all possible colored objects.

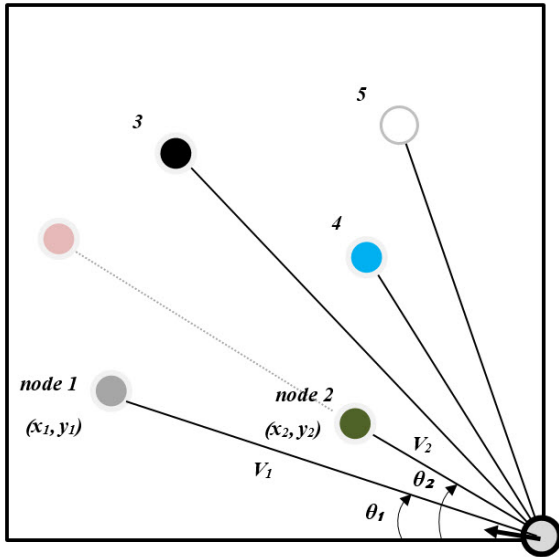

Fig. 3 The distances and absolute locations estimation using beacon node 2.

C. Matching the Absolute Locations Algorithm

This algorithm is used to recognize the exact color and location for each visible object in the environment. This process is done by searching for symmetry in locations between any object in

matrix A_2 with any object in matrix A_3 . Both matrixes contain are obtained from the reading of both beacon nodes as indicate in the last section. The color of any object and its location are distinguished when the matching occurs as shown in Fig. 4. The recognition process for the multi-color objects is accomplished according to following steps:

Step1: starting from the first object scanned by first beacon node choose the first row in it is matrix A_2 . This row represents the first possible location of this object and it has the same color of the object 1 in TABLE I.

Step2: For the first object scanned by beacon node 2, repeat to match all rows in matrix A_3 of this object with the row chosen in step 1. If the matching occurs then both the objects are remark as matched objects. In this case, the object chosen in step 1 is the first object in TABLE I and it has the same color.

Step3: If the matching does not occur step 2 is repeated for next object scanned by beacon node 2 until the matching occurs or ended all objects in the environment.

Step4: Repeat steps 1- 3 for other objects scanned by beacon node 1.

Step 5: Any object scanned by first or second beacon nodes and not marked by matched object is represented as an invisible object. The invisible object is the object that shown by one beacon node and not shown by another node. These invisible objects are localized in the next subsection.

There is an important notice must be taken in account when computing the absolute location of any colored object. Each color object location can be computed in one of three methods according to information about that object, as shown in Fig. 5: Method 1: Use (8) to compute the absolute location of the first object:

$$\left. \begin{aligned} x &= x_1 + d_1 \cos \theta_1 \\ y &= y_1 + d_1 \sin \theta_1 \end{aligned} \right\}. \quad (8)$$

Where d_1 is the distance between beacon node 1 and object 1 and θ_1 are the orientation of object 1 with respect to the beacon node 1.

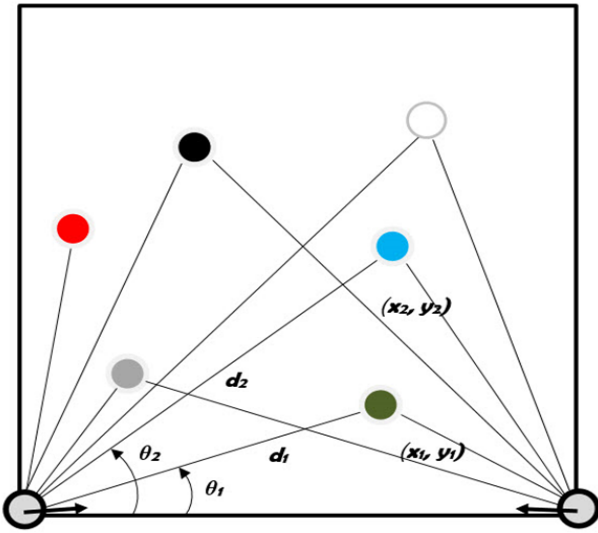

Fig. 4 Matching between object locations depending on reading of both beacon nodes.

Method 2: Use (8) to compute the absolute location of the first object:

$$\left. \begin{aligned} x &= x_2 + d_2 \cos \theta_2 \\ y &= y_2 + d_2 \sin \theta_2 \end{aligned} \right\} \quad (9)$$

Where d_2 is the distance between beacon node 2 and object 1 and θ_2 is the orientation of object 1 with respect to the beacon node 2.

Method 3: Use the law of sine to compute the distance d_2 and d_1 between the object and the two beacon nodes as shown in Fig. 5.

$$\frac{d_1}{\sin \theta_2} = \frac{d_2}{\sin \theta_1} = \frac{d_3}{\sin \theta_3} \quad (10)$$

Where

$$d_3 = \sqrt{(x_2 - x_1)^2 + (y_2 - y_1)^2} \quad (11)$$

and

$$\theta_3 = 180 - (\theta_1 + \theta_2) \quad (12)$$

Use (7) or (8) to compute the absolute location of the object.

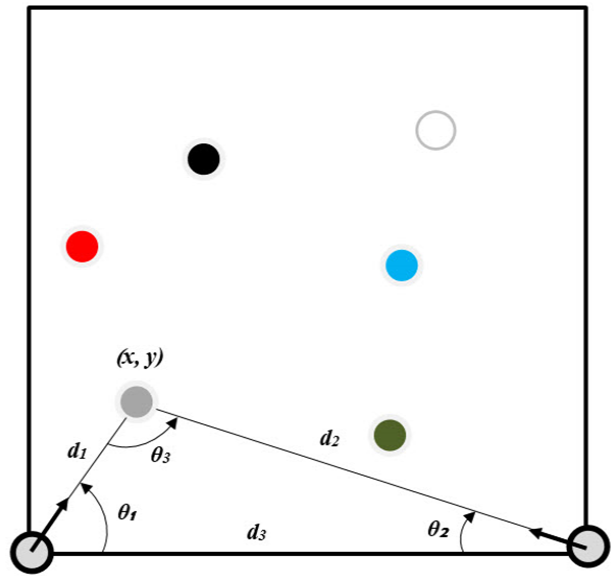

Fig. 5 Computing the absolute location of any colored object.

Fig. 6 shows that the maximum error to estimate the location of any object is increase as the distance between the object and beacon node increase. The error e_2 is greater than the error e_1 because the distance d_2 is greater than the distance d_1 . This assumption helps us to distinguish which is the best method to compute the absolute location.

From Fig. 5, we found that method 1 is better than method 2 to compute the exact location of object 1 because the object is nearest to the beacon node 1. Also by comparing method 1 and method 3, we found that in method 3, the process for calculating the absolute location of object 1 is obtained with respect to either beacon node 1 or node 2. In both cases, the distances from object 1 to beacon nodes (d_1 or d_2) is computed by the law of sine which dependent on orientations of object 1 with respect to beacon node 1 or node 2 (θ_1 or θ_2). Since these computations dependent on distances and orientations to beacon nodes so that the error to estimate the exact position of object 1 is come from error in orientation and from error in the distance which is also dependent on orientation to beacon node. From that, we found that method 1 is less error than method 3 because the error in method 1 comes only from the orientation of object 1 to the beacon node 1.

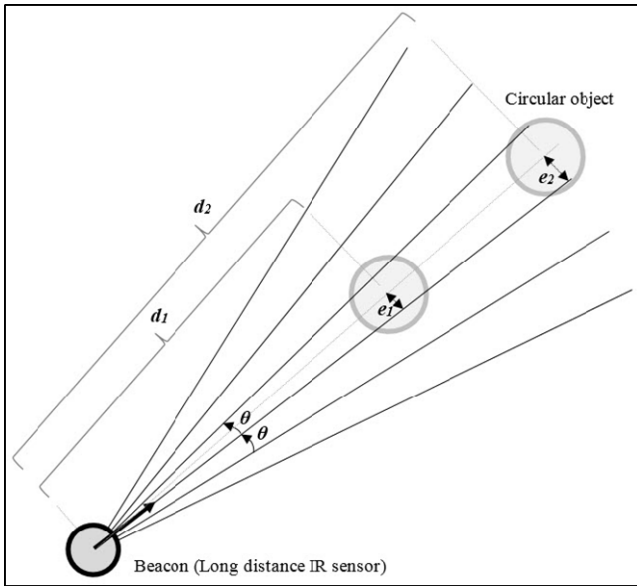

Fig. 6 The maximum possible error in estimation the location of any object.

D. Absolute Locations of Invisible Color Objects

Some of the objects are invisible to one of the beacon nodes so that they are not localized in the last subsection as shown in Fig. 7. The invisibility means that the location of this object is behind one of other visible objects. This algorithm is used to estimate the absolute location of these objects by assuming that the invisible object is placed behind each of the visible objects. Then the locations of all these assuming objects are computed by using the TABLE I and the law of sine. One of these computed locations is the correct location since it is produced the exact distance to the other beacon node. The process of estimation the location of any invisible object is indicated in the following steps:

Step1: Starting from the first color object to the last one which scanned by beacon node 1 search for object remark as not matched (invisible object). If the invisible color object is found then choose it is voltage (v) and orientation θ from matrix A_1 in subsection B.

Step2: For the invisible colored object with voltage (v) compute the matrix, A_2 depending on all the possible colored objects obtained from TABLE I. One row of this matrix contains the actual information of the invisible colored object.

Step3: Since the invisible object not shown by beacon node 2 so that it lies behind one of the visible colored objects. Fig. 8 shows an environment with a red object that it is invisible

to beacon node 2. To localize this object, we assume it lies behind one of another visible object. We express for this object by O_a (lies behind of gray object), O_b (lies behind of green object) and O_c (lies behind of black object). Other color objects are omitted because they produce locations to invisible object out the range of environment.

Step4: To compute the distances and the absolute locations for these purpose color objects we use the law of sine. For example, to compute the distance between first beacon node and the O_a object in Fig. 8 we use the law of sine shown in (13):

$$\frac{d_a}{\sin\theta_1} = \frac{d}{\sin\theta_a} \tag{13}$$

$$\theta_a = 180 - (\theta_1 + \theta) \tag{14}$$

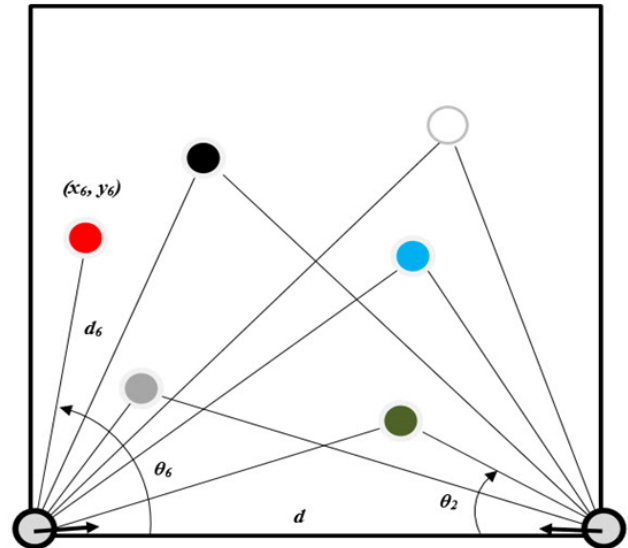

Fig. 7 Illustration of the absolute location of invisible object.

The absolute location of the O_a object is computed from (15):

$$\left. \begin{aligned} x_a &= x_1 + d_a \cos\theta \\ y_a &= y_1 + d_a \sin\theta \end{aligned} \right\} \tag{15}$$

Step5: starting from the first row in matrix A_2 , which build in step 2, compare the absolute location for matching with the absolute locations of purpose objects. The occurrence of matching means that the invisible object has the same color

of the first row and has the same absolute location of the matched purpose object.

Step 6: Repeat steps 1 to 5 to localize the invisible colored objects by beacon node 1.

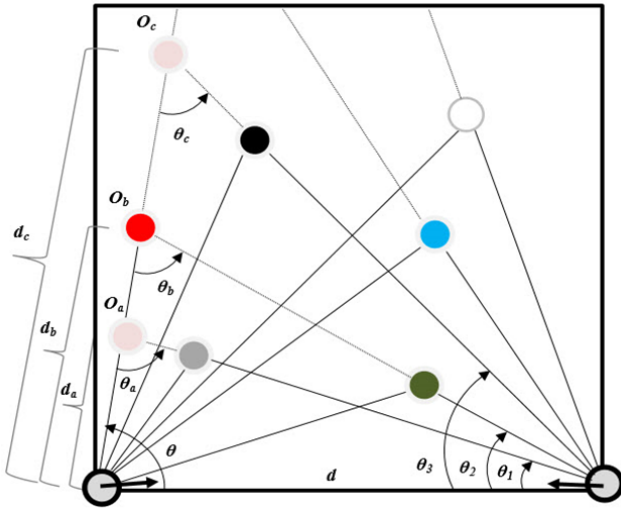

Fig. 8 Illustration of the purpose objects to the invisible objects.

III. EXPERIMENTAL RESULTS

The locations matching algorithm is used to achieve the multi-color objects localization and recognition. This algorithm is validated in experiments using microcontroller kit, servo motors, long distance IR sensors and computer. Each experiment was implemented over 100 different randomly distributed of colored objects with a different number (n) of objects ranging from two to 15. All experiments are implemented on a square area of side length 80 cm. In addition, the radius (R) for each colored object was changed in order to indicate the relation between the size of the object and the actual location of this object. So that, the parameters used in these experiments are:

1. The color of object c : the output characteristic of long distance IR sensor changed with the color of the object and with the smoothness of the object surface.
2. The distance between the object and beacon node d : the accuracy in the localization of any object changes with distance between the object and beacon node.
3. The radius of object R : the accuracy in estimation the location of any object depending on its radius.

4. The number of the objects in environment n : the visibility of any object is affected by the changing of the number of objects.

Fig. 9 shows the circuit diagram of the first experiment. This circuit consists of microcontroller kit, Sharp long distance IR sensor, six colored objects, and computer. The purpose of this experiment is to evaluate the look-up table as shown in TABLE II. Each column in this table is computed for the different color object. The values in these columns are obtained by changing the distance between the long distance IR sensor and the color object. Fig. 10 shows the actual picture of this experiment.

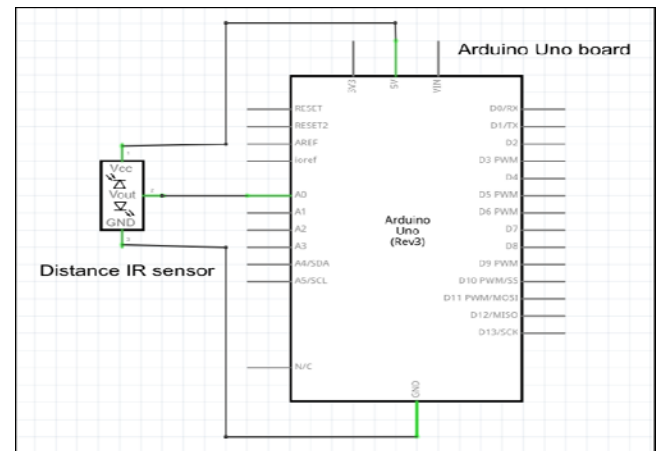

Fig. 9 Circuit diagram to evaluate the look-up table of different color objects.

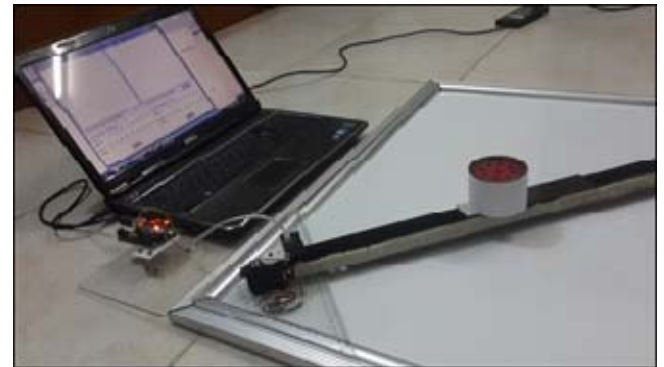

Fig. 10 The experiment set-up to evaluate the look-up table.

The second experiment was performed over topology represent a network with six color objects. The objects were randomly placed on 80x80 cm uniform distribution area as shown in Fig. 11. This circuit consists of microcontroller kit, two of Sharp long distance IR sensors, two servo motors, six colored objects and computer.

Fig. 12 shows the circuit diagram for this experiment. The purpose of this experiment is to achieve the multi-color objects localization and recognition.

TABLE II

The output voltages of the Sharp long distance IR sensor for different colored objects.

Output voltage (V) Distances (cm)	Object 1 white	Object 2 red	Object 3 gray	Object 4 blue	Object 5 green	Object 6 black
0	0	0	0	0	0	0
5	0.93	0.76	0.59	0.65	0.84	0.48
10	1.59	1.45	1.24	1.3	1.49	1.1
15	2.45	2.44	2.2	2.27	2.14	1.75
20	3.31	3.15	2.84	2.86	2.65	2.4
25	3.7	3.5	3.26	3.1	2.94	2.8
30	3.34	3.24	3.14	2.96	2.82	2.68
35	3.1	2.99	2.9	2.73	2.5	2.3
40	2.92	2.78	2.67	2.46	2.25	2.1
45	2.67	2.53	2.41	2.2	2	1.85
50	2.41	2.32	2.2	2.02	1.83	1.7
55	2.22	2.08	1.98	1.82	1.68	1.55
60	2.04	1.94	1.82	1.7	1.54	1.38
65	1.88	1.79	1.67	1.5	1.36	1.2
70	1.74	1.66	1.55	1.36	1.22	1.11
75	1.61	1.52	1.42	1.26	1.12	1
80	1.53	1.41	1.32	1.15	1.02	0.9
85	1.46	1.33	1.22	1.05	0.94	0.82
90	1.4	1.28	1.18	1	0.86	0.74
95	1.38	1.24	1.14	0.95	0.8	0.68
100	1.35	1.2	1.1	0.93	0.78	0.66

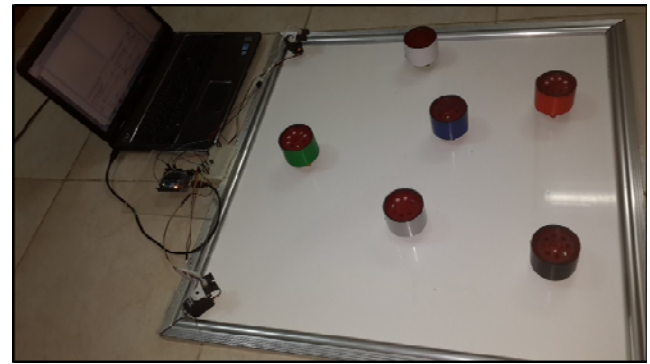

Fig. 12. The experiment set-up to achieve the multi-object localization and recognition.

A further experiment is intended to show the maximum capacity of color objects that can be used with the locations matching algorithm.

The last experiment is implemented for a different number of beacon nodes starting from one to four beacons placed at corners of the environment. The experiment is repeated for a different number of objects starting from one to fifteenth objects, and for different sizes: 1.5 cm radius, 2.5 cm radius, and 3.5 cm radius. The purpose of this experiment is to indicate the influence of opacity. The opacity is occurring with object invisible to all beacon nodes.

The purpose of these experiments is to evaluate the performance of the locations matching algorithm. The following performance metrics are used:

1. The accuracy of object localization (AL): this metric measure the amount of error occurs in the localization of the multi-color objects in the environment has two beacon nodes placed at two corners. The error is tested with respect to the distance between the object and beacon node and with respect to the size of the object.
2. Maximum capacity of color objects (MC): this metric test the maximum number of color objects that used to satisfy the locations matching algorithm. The objects used in this test have different colors and different reflection factor.
3. Percentage of objects opacity (OO): this metric tests the percentage of objects which invisible by all of the beacon nodes. The term opacity means that object cannot be localized by the locations matching algorithm because all it is not shown by the beacon nodes in the environment.

The main goals behind these experiments are to show that the investigation of the object localization matching algorithm is dependent on

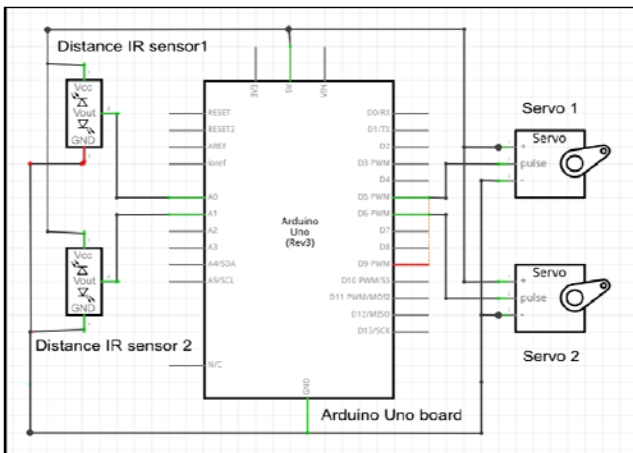

Fig. 11 Circuit diagram to investigate the object locations matching algorithm.

the careful selection of input parameters (c, d, R, n). We start by studying the effect of choosing the surface of the object with a suitable degree of smoothness and a suitable color on the output voltage of long distance IR sensor. In addition, the change of distance between the colored object and beacon node gives complete characteristic to this sensor as shown in Fig. 13. It appears that the white object with more smoothness surface produce a higher curve in characteristic and the black object with less smoothness surface produce a lower curve in characteristic.

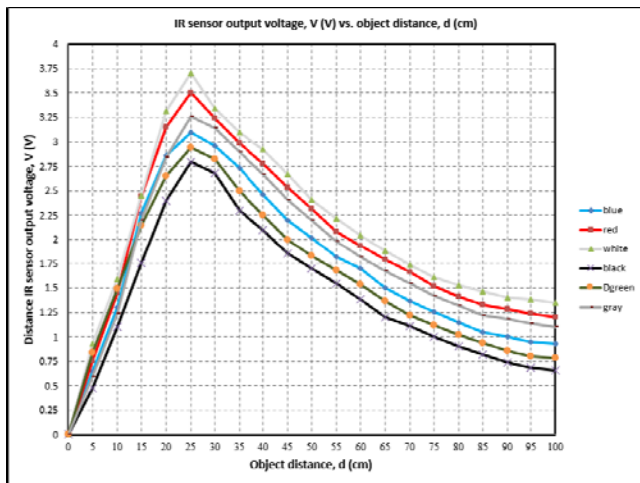

Fig. 13 The output characteristics of the Sharp long distance IR sensor for different color and different smoothness surface.

Fig. 14 shows the effect of change the distance between beacon node and color object on the accuracy to estimate the correct location of the object. As the distance is increased, also the median error increased. In addition, the change in radius of the object leads to change in the median error. The object with smaller radius has a less median error to estimate the absolute location of the color object. The locations matching algorithm has three methods to compute the absolute location of colored objects. TABLE III shows that method 1 is the best choose to reduce error in estimation the absolute locations of objects.

The maximum capacity of color objects are used with the locations matching algorithm is indicated in Fig. 15. TABLE II shows that the maximum output voltage for the Sharp long distance IR sensor is obtained when the reflecting object has a white color with higher smooth surface and the minimum output voltage is obtained when the

reflecting object has black color with the lower smooth surface. Fig. 13 indicates that the voltage range of output long distance IR sensor has a maximum boundary which limited by the white and black object and it is about 0.6 volt. The maximum capacity of color objects is computed as follows:

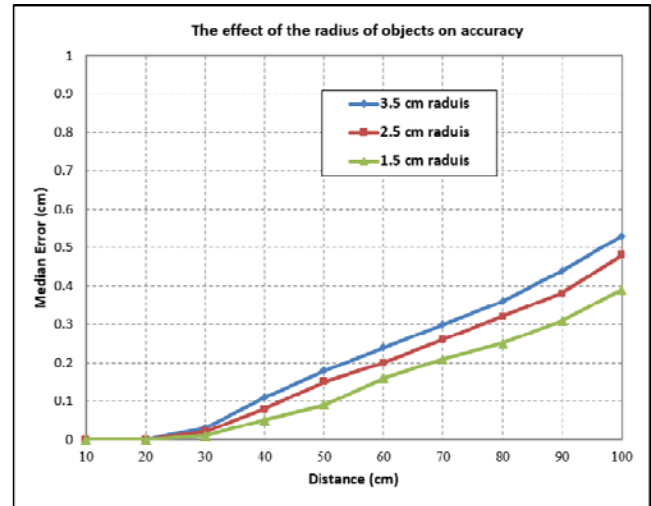

Fig. 14 The median error in estimation the absolute location of the object with different radius size and different distances.

TABLE III

Comparison among the three methods to estimate the locations of objects.

Median error (cm) \ Distances (cm)	Method 1	Method 2	Method 3
25	0.01	0.02	0.04
50	0.09	0.11	0.18
75	0.23	0.29	0.36
100	0.38	0.46	0.65

From Fig. 14 we notice that the suitable object for our algorithm is one with radius 1.5 cm because it produces a less median error for computing the absolute location of that object. The maximum error is 0.4 cm occurs for a distance equal to 100 cm between the beacon node and the object. To express this error in voltage we used the linear interpolation formula as shown in (2) and Fig. 2. Since the curves in Fig. 13 show the same slopes so that we used the white object for our calculations. For distance from 40 cm to 45cm, the output voltage changes from 2.9 V to 2.65 V. According to (2) let $X_a = 40$ cm, $X_c = 45$ cm, $V_a =$

2.9 V, and $V_c = 2.65$ V. $X_b = X_a +$ maximum error = $40 + 0.4 = 40.4$ cm.

$$X_b = X_a + (V_b - V_a) * (X_c - X_a) / (V_c - V_a)$$

$$V_b = V_a + (X_b - X_a) * (V_c - V_a) / (X_c - X_a)$$

$$V_b = 2.9 + (40.4 - 40) * (2.65 - 2.9) / (45 - 40) = 2.88V$$

The maximum error = $2.9 - 2.88 = 0.02$ V

Since the error occur in both sides of object as shown in Fig. 6, so that we duplicate the maximum error.

The maximum error = $2 * 0.02 = 0.04$ V

The maximum capacity = maximum range / maximum error = $0.6 / 0.04 = 15$ color objects.

Fig. 15 shows the output characteristics of the Sharp long distance IR sensor with 10 different color objects. It is represented Fig. 13 after adding 4 color objects. The maximum number of color objects that can be added to this figure is 15 objects which represent the maximum color objects can be used with the object localization matching algorithm.

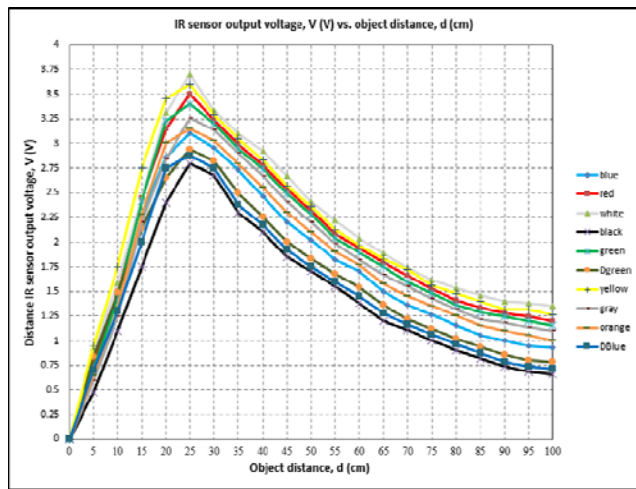

Fig. 15 The output characteristics of the Sharp long distance IR sensor with 10 different color objects.

Figures 16, 17, 18, and 19 indicate the relationship between the percentage of opacity and the number of color objects. This relationship is repeated to the different size of color objects: 1.5 cm radius, 2.5 cm radius, and 3.5 cm radius. In addition, the number of beacon nodes changed for each figure. It appears that the opacity increases as the number of objects increase. In addition, the opacity increases as the size of objects increase. Finally, the increment in a number of beacon nodes decreases the opacity.

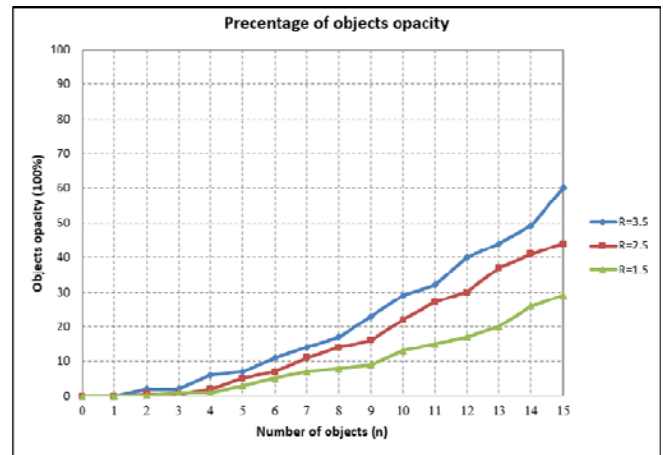

Fig. 16 The percentage of node opacity vs. the number of color objects (1-beacon node environment).

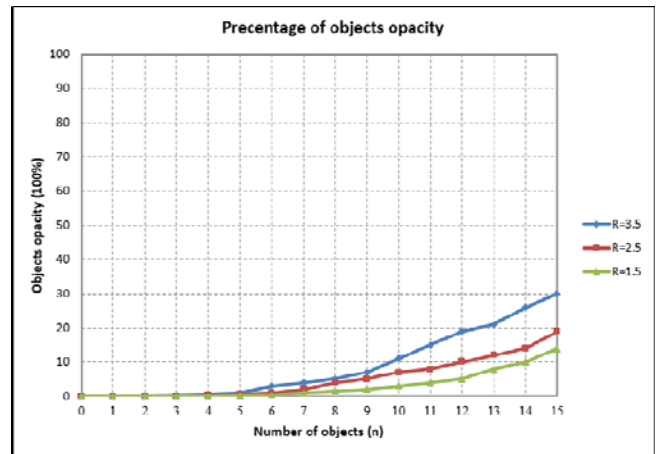

Fig. 17 The percentage of node opacity vs. the number of color objects (2-beacon nodes environment).

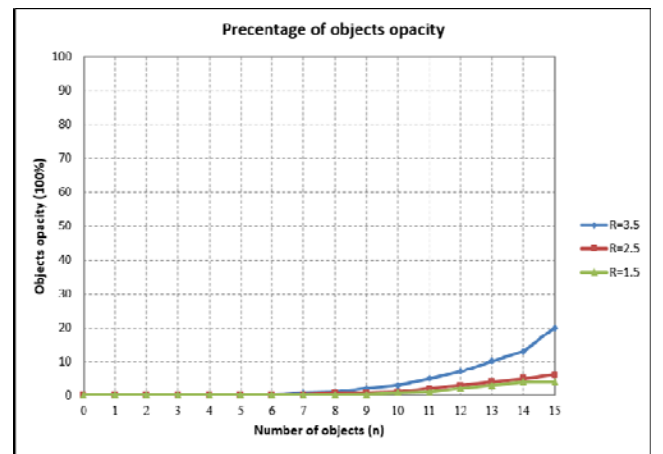

Fig. 18 The percentage of node opacity vs. the number of color objects (3-beacon nodes environment).

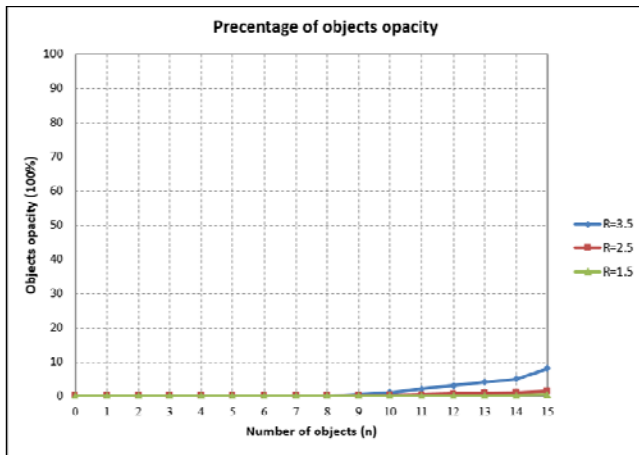

Fig. 19 The percentage of node opacity vs. the number of color objects (4-beacon nodes environment).

IV. CONCLUSIONS

In this paper, a new algorithm for multi-color objects recognition and localization is introduced. The idea of this algorithm is based on a search for matching between the locations of objects that stored in two matrixes. Both matrixes are obtained from the reading of two beacon nodes which have two sharp long distance IR sensors. A look-up table is used to convert the reading of the distance IR sensors from voltages to distances. The locations matching algorithm is suitable for an environment with a small number of objects. Each object has a surface with different color and different degree of smoothness. This algorithm needs two beacon nodes fixed at two corners of the environment. In addition, these results show that the maximum capacity of color objects that used with this algorithm is 15 color objects. One of these experiments is used to perform the locations matching algorithm over topology represent the network with six color objects. From the experimental results, the accuracy to estimate the correct location of the object is found dependent on the radius of color objects and the distances between beacon nodes and these objects. As the distance increased, the median error also increases and as the radius of object decrease, the median error is decreased. The experimental results tested the opacity for a different number of color objects, the different radius of color objects and a different number of beacons. According to these result, we found that the color objects with 1.5 cm radius are better

chosen for the object locations matching smaller percentage of opacity and produce a less median error for computing the absolute location of that object. An environment with 9 to 10 color objects is suitable to investigate our algorithm because the percentage of opacity, in this case, is approximately zero. Finally, the two-beacon nodes environment is more suitable to implement our algorithm. In the implementation of the current algorithm, the circular shape objects are used. The different shapes of the objects are suggested for future work. This algorithm implemented for stationary objects in the environment. The extension to the mobile objects case is straight forward.

REFERENCES

- [1] P. Rawat, K. D. Singh, H. Chaouchi, J. M. Bonnin, "Wireless sensor networks: a survey on recent developments and potential synergies," *The Journal of Supercomputing*, vol. 68, Issue 1, April 2014, pp. 1–48.
- [2] A. Marjovi, L. Marques, "Multi-robot olfactory search in structured environments," *Robotics and Autonomous Systems* vol.52, 2011, pp.867–881.
- [3] A. T. Rashid, M. Frasca, A. A. Ali, A. Rizzo, L. Fortuna, "Multi-robot localization and orientation estimation using robotic cluster matching algorithm", *Elsevier / Robotics and Autonomous Systems*, vol.63, Part 1, January 2015, pp. 108-121.
- [4] T. Arampatzis, J. Lygeros, S. Manesis, "A Survey of Applications of Wireless Sensors and Wireless Sensor Networks," *Intelligent control, Proceedings of the 2005 IEEE International Symposium on, Mediterranean Conference on Control and Automation*, 2005, pp.719 – 724.
- [5] M. P. Durisic, Z. Tafa, G. Dimic, V. Milutinovic, "A survey of military applications of wireless sensor networks," *Conference on Embedded Computing (MECO)*, 2012, pp.196 – 199.
- [6] O. A. Hasan, A. T. Rashid, R. S. Ali, "Hybrid approach for multi-node localization and Identification", *Basrah Journal for Engineering Sciences*, vol.16, No 2, 2016, pp. 11-20.
- [7] R. Tron, J. Thomas, G. Loianno, K. Daniilidis, V. Kumar, "A Distributed Optimization Framework for Localization and

Formation Control: Applications to Vision-Based Measurements,” *IEEE Cont. Sys. Mag.*, vol. 36, no. 4, 2016, pp. 22-44.

[8] G. A. Kaminka, R. Schechter-Glick, and V. Sadov, “Using sensor morphology for multi-robot formations,” *IEEE Transactions on Robotics*, vol.24, no. 2, 2008, pp. 271–282.

[9] K. Chintalapudi, R. Govindan, G. Sukhatme, A. Dhariwal, “Ad-hoc Localization Using Ranging and Sectoring,” In *InfoCom*, 2004.

[10] loukas Lazos, R. Poovendran, “SeRLoc: Secure Range-Independent Localization for Wireless Sensor Networks,” In *WiSe*, 2004.

[11] O. A. Hasan, R. S. Ali, A. T. Rashid, “Centralized approach for multi-node localization and identification”, *Iraq J. Electrical and Electronic Engineering*, vol.12, No 2, 2016, pp. 178-187.

[12] O. A. Hasan, A. T. Rashid, R. S. Ali, J. Kosha, “A practical performance analysis of low-cost sensors for indoor localization of multi-node systems”, *International Conference on Internet Technologies & Applications*, 2017, pp. 284-287.

[13] H.Ruser, “Object recognition with a smart low-cost active infrared sensor array,” *1st International Conference on Sensing Technology*. November 2005, pp. 21-23.

[14] Billur Barshan, Tayfun Aytac, “Position-invariant surface recognition and localization using infrared sensors,” *Opt. Eng.* , vol.42, no. 12, 2003, pp.3589–3594.

[15] M.R. Yaacob, N.S.N. Anwar, A.M. Kassim, “Effect of Glittering and Reflective Objects of Different Colors to the Output Voltage-Distance Characteristics of Sharp GP2D120 IR”, *ACEEE Int. J. on Electrical and Power Engineering*, vol.03, No. 02, 2012.